



HC9621FR

Ceramic hob

Installation, use and maintenance



Contents:

3	Important
5	Important information
6	Using your hob
8	Operating time limiter
9	Triple zone function
9	Dual zone function
10	Auto-heat function
12	Timer
13	Safety key lock
14	Residual heat indicators
14	Efficient use of your hob
16	Care and maintenance
17	Cleaning guide
18	Troubleshooting
20 - 24	Installation
20	Installation - preparation
22	How to install the hob
24	Mains electrical connection
27	Energy efficiency information

Important

The CDA Group Ltd cannot be held responsible for injuries or losses caused by incorrect use or installation of this product. Please note that CDA reserve the right to invalidate the guarantee supplied with this product following incorrect installation or misuse of the appliance or use in a commercial environment.

This appliance is not designed to be used by people (including children) with reduced physical, sensorial or mental capacity, or who lack experience or knowledge about it, unless they have had supervision or instructions on how to use the appliance by someone who is responsible for their safety.

Under no circumstances should any external covers be removed for servicing or maintenance except by suitably qualified personnel.

Appliance information:

Please enter the details on the appliance rating plate below for reference, to assist CDA Customer Care in the event of a fault with your appliance and to register your appliance for guarantee purposes.

Appliance Model	
Serial Number	

EU Declarations of Conformity

This appliance has been manufactured to the strictest standards and complies with all applicable legislation, including Electrical safety (LVD) 2014/35/EU and Electromagnetic interference compatibility

(EMC) 2014/30/EU. Parts intended to come into contact with food conform to 1935/2004/EC.

IMPORTANT INFORMATION FOR CORRECT DISPOSAL OF THE PRODUCT IN ACCORDANCE WITH EU DIRECTIVE 2012/19/EU.

At the end of its working life, the product must be taken to a special local authority waste collection centre or to a dealer providing appliance recycling services.

Disposing of a household appliance separately avoids possible negative consequences for the environment and health. It also enables the constituent materials to be recovered, saving both energy and resources. As a reminder of the need to dispose of household appliances separately, the product is marked with a crossed-out wheeled dustbin. 

Please note:

- Ceramic hobs become hot and remain hot during and immediately after use. Do not touch the hob until it has been allowed to cool.
- Keep children away from the appliance when in use.
- Never use the hob top for storage.
- Pan handles should never stand out beyond the edge of the worktop. This will help to avoid children reaching them.
- Do not lean over the hob when it is in use.
- Follow the cleaning instructions carefully.
- Ensure the base of the saucepan is clean and dry before placing it on the hob.
- Avoid hard shocks from cookware – the vitroceramic glass surface is highly resistant but not unbreakable.

- Do not place hot lids flat on the hob top. A “suction” effect could cause damage to the hob.
- Do not drag cookware across the hob top: in the long term, this could cause damage to the hob.
- Do not store cleaning or flammable products in the unit below the hob.
- Always use appropriate cookware.
- Do not cook unopened tins of food directly on the hob.
- Never put cooking foil or plastic materials on the ceramic surface when the hob is hot. These materials could melt and cause damage to the hob.
- This hob (Class 3) has been designed for use only as a cooking appliance. Any other use should be considered incorrect and therefore dangerous.

Important

- Do not use the hob if the glass surface is cracked or damaged to prevent the risk of electric shock. Disconnect it from the power supply.
- Ensure that the power cable of a connected electrical appliance near the hob is not in contact with the cooking zones.

Please note:

- When connecting the hob to the power and switching it on for the first time the cooking zone displays may show the letter "**H**". This is not a fault and the letter "**H**" should disappear after approximately one hour. Please see page 14 for more information.
- The safety key lock may be active. Simply press and hold the safety key lock sensor (2) for three seconds to deactivate it.

Using your hob

Zones:

1. Front left 2.3kW Ø210/175/120 mm
2. Back left 1.2kW Ø145 mm
3. Central 2.2kW Ø170 x 265 mm
4. Back right 1.8kW Ø180 mm
5. Front right 1.2kW Ø145 mm

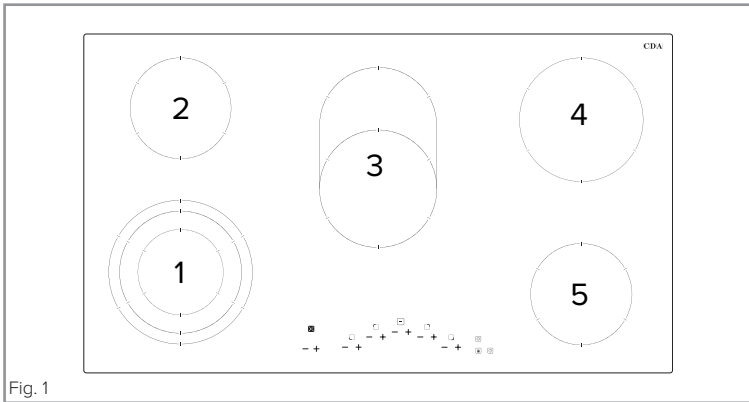

Fig. 1

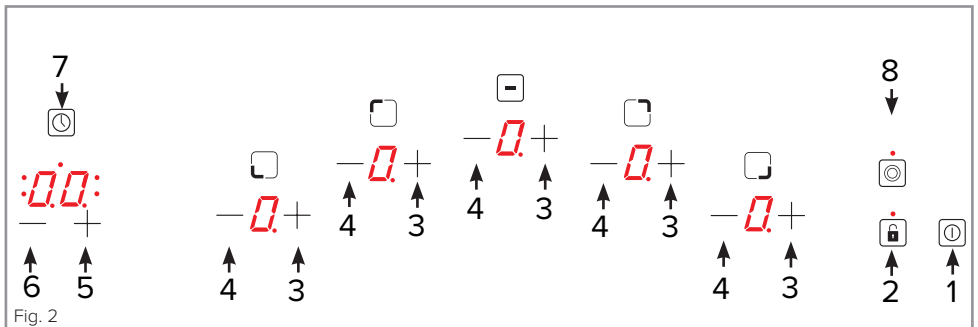

Fig. 2

Control panel:

1. On/off sensor
2. Safety key lock sensor
3. Zone plus setting sensor
4. Zone minus setting selector
5. Timer plus setting sensor
6. Timer minus setting sensor
7. Timer sensor and display
8. Triple zone sensor

To switch the hob on

- To switch the power on, touch and hold the on/off sensor (1) ⊕ for approximately two seconds. The hob will beep and all five cooking zone indicators will show '0'.

Please note: If a power level is not set within ten seconds, the hob will switch off automatically.

After switching the mains supply on to the hob, or if the mains supply is interrupted and then restored, the safety key lock may be activated. The safety key lock LED will be on to indicate this. Simply press and hold the safety key lock sensor (2) for approximately two seconds to deactivate the safety key lock and proceed to use the hob as normal.

The safety key lock also activates after 60 seconds if the appliance is switched off via the 'On/off sensor' (1). This is to help to prevent accidental use. Simply follow the same step as above to deactivate the safety key lock.

To set the power level

- After switching the hob on, simply select the desired heat setting using the '+' or '-' selectors for that zone. The power level ranges from 1 (minimum) to 9 (maximum). The hob will then begin heating. You can also press the '-' selector first to jump straight to power level 9.

To turn the power off to a zone

- To switch off a zone you can use the zone's '-' selector to return the heat setting to 0 or alternatively you can press both the '+' and '-'

selectors simultaneously for that zone. The cooking zone indicator will display a '0' to confirm that the zone is now inactive.

- If switching off multiple zones, the above steps need to be taken for each zone. When all the zones are at '0', the hob will switch off automatically after approximately ten seconds.
- Alternatively, to switch off the hob immediately, touch and hold the 'On/off sensor' (1) ① for approximately two seconds.

Please note: Any zones that are still hot to the touch will display an "H" provided the mains power supply is not interrupted.

Operating time limiter

Each zone has an operating time limiter to increase overall efficiency and to prevent the hob from being left on indefinitely. If a zone's heat setting is not changed for a specific duration then the associated zone is automatically switched off and residual heat indicator activated. Zones can still be used as normal in accordance with the operating instructions. The operating time limiter is set according to the last selected heat setting. The maximum operating times for each setting can be found below.

Zone Power Level	1	2	3	4	5	6	7	8	9
Maximum Operating Time (hours)	10	5	5	4	3	2	2	2	1

Triple zone function

The front-left zone is equipped with a triple zone function that allows you to extend the heating area for the zone. In normal use, the zone functions with just the smaller inner ring until the triple zone function is activated.

To activate the triple zone function

- Simply set a power level on the front-left zone and then press the triple zone sensor (8) once to activate the middle zone and press it again to also activate the outer zone. The LEDs above the triple zone sensor (8) will illuminate accordingly (one for when the double zone is active and two for when the triple zone is active).

To deactivate the triple zone function

- Simply press the triple zone sensor (8) for a third time. Both LEDs either side of the triple zone sensor (8) should extinguish and the zone will return to operating on the inner zone only.

Dual zone function

The central zone is equipped with a dual zone function that allows you to extend the heating area for the zone. In normal use, the zone functions with just the lower circular ring until the dual zone function is activated.

To activate the dual zone function

- Simply set a power level on the central zone and then press the triple zone sensor (8) once to extend the zone. An LED above the triple zone sensor (8) will illuminate to show you that the dual zone

is active.

To deactivate the dual zone function

- Simply press the triple zone sensor (8) for a second time. The LED above the triple zone sensor (8) should extinguish and the zone will return to operating on the circular zone only.

Auto-heat function

- Every zone is equipped with an auto-heat function, which reduces the warming up time for the zone. To turn on the auto-heat function, the zone in question must first be set to heat setting 0.
- Touch the '-' sensor for that zone once. The heat setting will be set to '9'. The zone display will alternate between '9' and the letter 'A'.
- Next, adjust the zone to the desired heat setting between 1 and 8. The decimal point next to the set power level will flash and then remain solidly lit for a preset period of time before reducing the power to the originally selected heat setting. The duration of each auto-heat setting's limiter is shown in the table on the following page.
- To disengage the auto-heat function simply touch both the '+' sensor and the '-' sensor simultaneously for that zone. The cooking zone indicator should revert to 0. Alternatively, raise the power level by one level and then lower it by one.

A table showing the operating time limit of the auto-heat function for each power level is shown on the following page.

Zone Power Level	1	2	3	4	5	6	7	8	9
Maximum Operating Time (minutes)	1.11	2.44	4.47	5.28	6.29	1.11	2.44	2.44	--

Please note: The auto-heat function is not compatible with heat setting 9.

If a power level (between 1 and 8) is not selected within 10 seconds of preparing the auto-heat function, then the function will be deactivated.

Timer

The hob is equipped with a timer that allows a finish time to be set for the end of cooking on any zone, between a minimum of 1 minute and a maximum of 99 minutes. This timer can only be used on one zone at a time. Once the timer is set, the timer display will show the time remaining. In normal use, the timer ending prompts the zone heating to end as well.

To set the timer

- First switch on the hob if necessary and set the zone you'd like to be time to the required power level. Next, touch the timer sensor. This will activate the timer.
- A decimal point (LED indicator) should appear next to the timer display.
- Finally, set the number of minutes on the timer using the timer '+' or '-' sensors. A maximum of 99 minutes can be set.
- Once the time has elapsed the hob will emit an acoustic signal and the zone will cease operation. To cancel the acoustic signal simply press any sensor field.

To cancel the timer

- Simply touch the timer sensor and use the timer '-' sensor to return the number of minutes to '0'. The timer will then be cancelled.

Please note: Activating the timer sensor will automatically take you to the 99 minute limit of the timer/minute minder. This is useful if you wish to set a large number of minutes (e.g. 90) but you cannot go back to 0 without cycling down through all of the minutes or turning the hob off and then on again.

Safety key lock

To prevent accidental use, the hob has a safety key lock which switches controls off temporarily or completely. The safety key lock can be activated when the hob is turned on but not when power has been switched off at, or the appliance disconnected from, the mains. The safety key lock is automatically activated after mains power supply has been restored.

To activate the safety key lock

With the hob either on or off, then simply touch the safety key lock sensor (2) for approximately 2 seconds. The hob will beep and the safety key lock LED should illuminate.

To deactivate the safety key lock

Simply touch and hold the safety key lock sensor (2) for approximately 2 seconds. The hob will beep and the safety key lock LED should extinguish.

Please note: The safety key lock may activate when the power supply is activated for the first time or resumed after an interruption. Simply deactivate the safety key lock as per the above step and proceed to use the hob as normal.

Residual heat indicators

The hob is equipped with residual heat indicators to warn when any of the zones are still hot to the touch after use. An 'H' will show in a zone's indicator if the relevant zone is hot. You should avoid touching any zone whilst the hob is in use, whilst residual heat indicators are displayed and even for some time afterwards.

Please note: In the event of a power cut or failure, the residual heat indicators will not illuminate after the power supply is restored. Also, when there is no power supply to the hob the residual heat indicators will not work, yet in both instances the hob zone(s) may still be hot, so extra care must be taken.

Efficient use of your hob

The hob is equipped with zones designed to accommodate most shapes and sizes of pan. For best results, only use pans with flat bottoms. The most efficient use of the hob is shown below, where the pan and zone are correctly chosen. Use pan lids where possible to minimize the energy usage of your appliance.

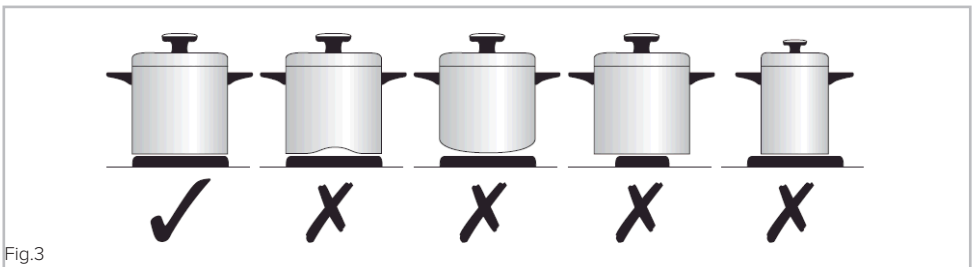

Fig.3

Zone Size	Minimum Pan Size (mm)	Maximum Pan Size (mm)
Ø 120mm	120	230
Ø 145mm	125	165
Ø 175mm	160	190
Ø 180mm	160	200
Ø 210mm	190	230

Please note: When using the dual zone function on the central zone, we recommend using pans that fit within the zone markings (i.e. oval hob-proof casserole dishes, sizzle platters etc.). This allows you to safely use the other zones.

Locating a pan in the centre of the zone markings will ensure optimum efficiency.

It is very important that the pans used on the hob are made of a suitable material and have the correct type of base. The base of the pan and the hob top must be clean before use to prevent any scratches on the hob top.

Please note: Extra care should be taken if cast iron pans are used as these have coarse bases which may damage the hob top.

Always take care when handling pans and pots that have been used on the hob as their handles may be hot to the touch. It is recommended that you use suitable protection for your hands when handling pots and pans.

Care and maintenance

Always disconnect the appliance from the power supply before undertaking any cleaning or maintenance.

Important:

- Steam cleaners must not be used when cleaning this appliance.
- You should use a non-abrasive cleaner to clean the hob top. Any abrasive cleaner (including Cif) will scratch the surface and could erase the control panel markings.
- Sugar and starch can cause permanent damage to the surface of the hob. Wipe away any spillages immediately but be careful given that the hob top will be hot during and after usage.
- Avoid letting pans boil over where possible to ensure that the need for cleaning is minimal.
- Always use a soft sponge or cloth where possible. Utensils such as scouring sponges and some brushes could cause scratches to the hob top.

A cleaning guide is available on page 17.

Type of residue	Clean with	Cleaning advice
Light	Cleaning sponge and soft cloth	Wipe over the zone to be cleaned with a sponge and hot water, and then wipe off with a soft dry cloth.
Accumulated baked-on stains/dirt, sugar spills or melted plastics	Cleaning sponge or glass scraper and soft cloth	Wipe over the zone to be cleaned with a sponge and hot water, using a ceramic scraper to remove any large marks or stains and then wipe off with a soft dry cloth.
Rings and hard water residues	White vinegar and soft cloth	Pour a small amount of warm white vinegar onto the stain, leave it to stand, and then wipe off with a soft dry cloth.
Shiny metallic streaks	Cleaning agent for vitroc ceramic glass	Use specialist vitroc ceramic glass cleaner (preferably one with silicone for its protective properties)

If your hob is not working:

1. Check that the zone is switched on.
2. Check that the mains supply has not been switched off.
3. Check that the fuse in the spur has not blown.

In the event of a fault with the hob please advise CDA Customer Care.

Contact CDA Customer Care

A: Customer Care Department, The CDA Group Ltd, Harby Road,
Langar, Nottinghamshire, NG13 9HY

T: 01949 862 012 F: 01949 862 003

E: customer.care@cda.eu W: www.cda.eu

Troubleshooting

Problem	Possible Causes	Possible Remedy
The appliance does not work and no indicators are lit.	The appliance has no power	Check the fuse and replace if blown.
Sensor fields do not respond when touched.	Appliance is not turned on	Turn on the appliance
	A sensor field has been touched too briefly (less than a second)	Touch the sensor field again and for longer
	Multiple sensors have been touched/covered at the same time	Only touch one sensor field at a time unless instructed otherwise
	The safety key lock is engaged	Disengage the safety key lock as per page 13
The appliance does not respond and emits an extended beep	Improper use (wrong sensor fields touched or touched too briefly)	Switch the appliance off via the on/off sensor and at the mains and then switch the power and appliance on again
The appliance switches itself off	No heat level has been set within 10 seconds of activating the appliance	Switch on the appliance and set zone and heat setting without delay
	Sensor fields covered or dirty	Uncover or clean the sensor fields
A cooking zone switches itself off and a residual heat indicator is shown.	Operating time limiter has activated.	Nothing (see page 8)
	Sensor fields covered or dirty	Uncover or clean the sensor fields
	Electronic components have overheated	Nothing. Allow appliance to cool.

Problem	Possible Causes	Possible Remedy
Residual heat indicator has extinguished despite zone(s) still being hot.	The appliance has no power or the zone temperature is lower than the sensor can register.	Check the fuse and replace if blown.
One or more heating elements (glowing red area) is switching on and off periodically, producing a click when doing so.	This 'cyclic' function is normal for this hob. Ceramic zones produce high heat levels and as such cycle on and off, particularly on lower heat settings.	No action needed.
Hob top is broken, cracked and/or chipped.	Stop using the appliance immediately and switch the appliance off at the mains. Contact CDA Customer Care to arrange a repair (contact details on page 17).	
A fault has not been resolved by any suggested remedies or a fault code is displayed	Contact CDA Customer Care using the contact details on page 17 to arrange a service visit.	

Should any error code show on the zone displays, or the above steps not resolve an issue, please contact CDA Customer Care for assistance. Contact details are on page 17.

IMPORTANT - PLEASE NOTE: In the event of any breakage, crack or cracking – even minimal – of the vitroc ceramic glass, immediately disconnect your appliance to prevent a risk of electric shock and contact CDA Customer Care.

Installation - preparation

Unpacking the hob:

Take care not to lose, drop or mishandle any parts.

Fitting position of the hob:

This appliance must be installed a minimum of 55mm away from any adjacent vertical surfaces, e.g. a tall cupboard end panel. These dimensions are shown in Fig. 8 on page 22. If installing the hob in a cupboard unit, then we recommend the use of a partition panel.

Ventilation requirements:

This appliance must be installed to allow air to flow freely to the air intake and from the air outlet. An air gap of 10mm is recommended immediately below the hob. Failure to allow sufficient ventilation could cause problems with operation or damage to the hob and constitutes incorrect installation, which is not covered by the product's warranty (Figs. 4 and 5).

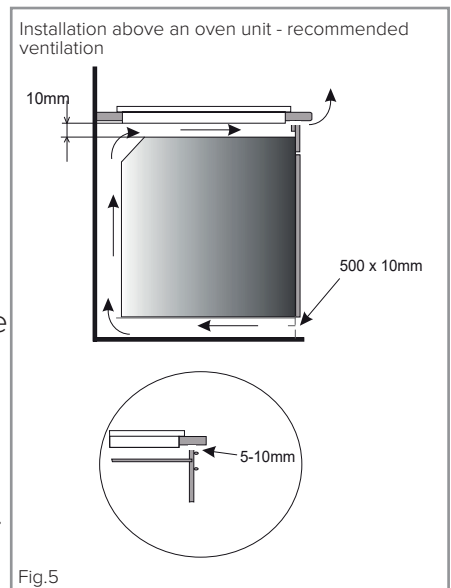
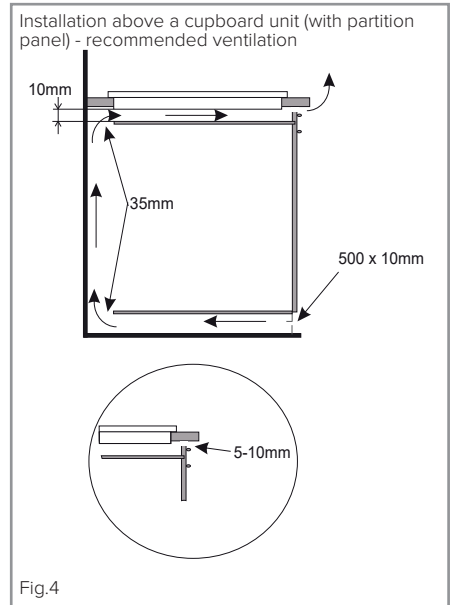

If fitting a CDA cooker hood above the hob:

If a CDA cooker hood is to be installed above the hob, the height of the hood above the hob must be at least 600mm (650mm is recommended) (Fig.6). If the instructions supplied with the hood dictate that the hood must be installed at a height greater than 600mm, then that height is the minimum required.

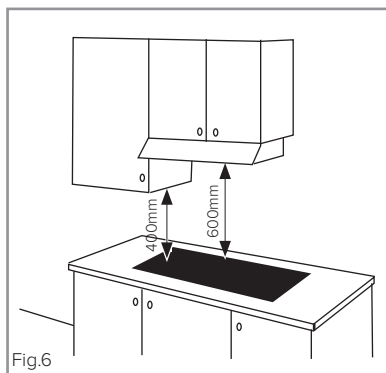

Wall furniture requirements:

The minimum height of any cabinet immediately above the hob is 750mm. The minimum height of any adjacent units (including light pelmets) is 400mm, unless they are manufactured from a material resistant to fire (steel, for example).

Important notes:

- Do not position this appliance above a refrigeration unit. The heat generated may cause the refrigeration unit to fail.
- This appliance is designed to be installed into cabinet units, and around worktops, capable of withstanding temperatures of 100°C+
- Never place perishable foods, cleaning products or flammable items in the cupboard below the appliance.
- If the hob is to be located above a working drawer, we recommend that the drawer is not used for storing soft items, for example dusters or towels; this is to minimise the risk of the cooling system air intakes being obstructed.
- Do not use silicone or similar sealants to seal the hob into place. It should always be accessible for servicing etc.

How to install the hob

Overall dimensions of the hob:

Width: 900 mm Depth: 518 mm

Worktop cut-out dimensions:

Width: 867 mm Depth: 490 mm

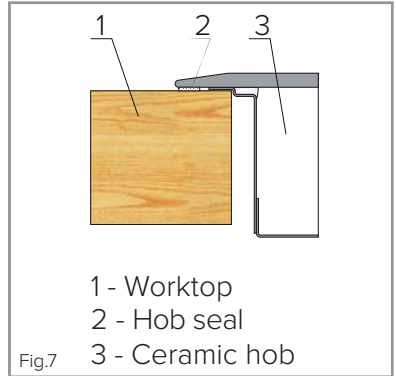

1. Make the required hole in the worktop.

Before doing this, you must check the

instructions supplied with any cooker hood to ensure that you will have the required clearance. The cutout in Fig. 8 shows a minimum of 50mm is required from the back of the cutout to the rear wall or splashback it is intended to be situated in front of.

2. Make sure that the worktop is clean and dust free and insert the hob into the cut-out opening. Press the hob firmly into place so that the seal connects with the worktop (Fig. 7).

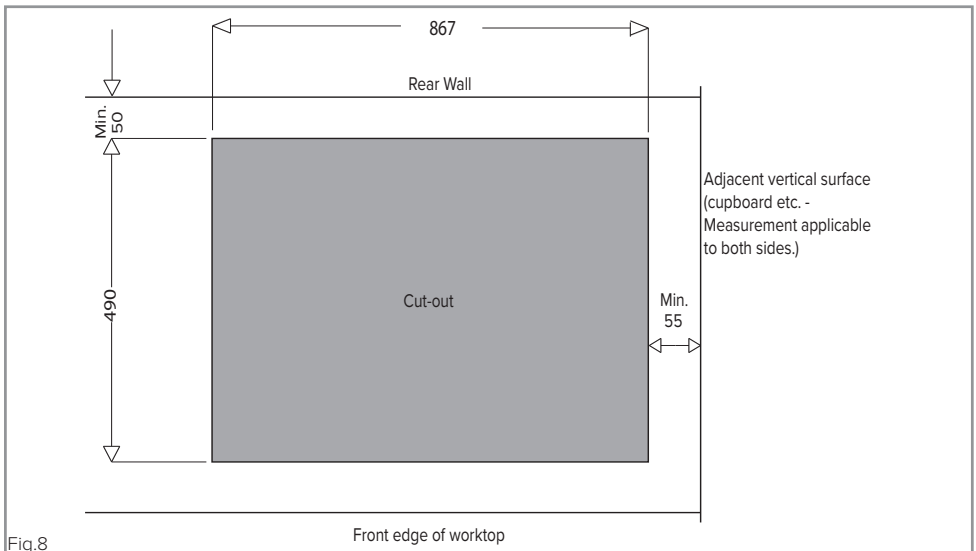

If fitting the hob into a 28-40mm worktop:

The four fixing clips supplied should be used. If fitting the hob into a thin worktop (i.e. 28mm), then we recommend using four 15x15x50mm wooden batons in addition to the brackets (as per figs. 9 and 10).

Position the fixing brackets perpendicularly to the hob's edge and tighten firmly. **Do not use power tools to do this.**

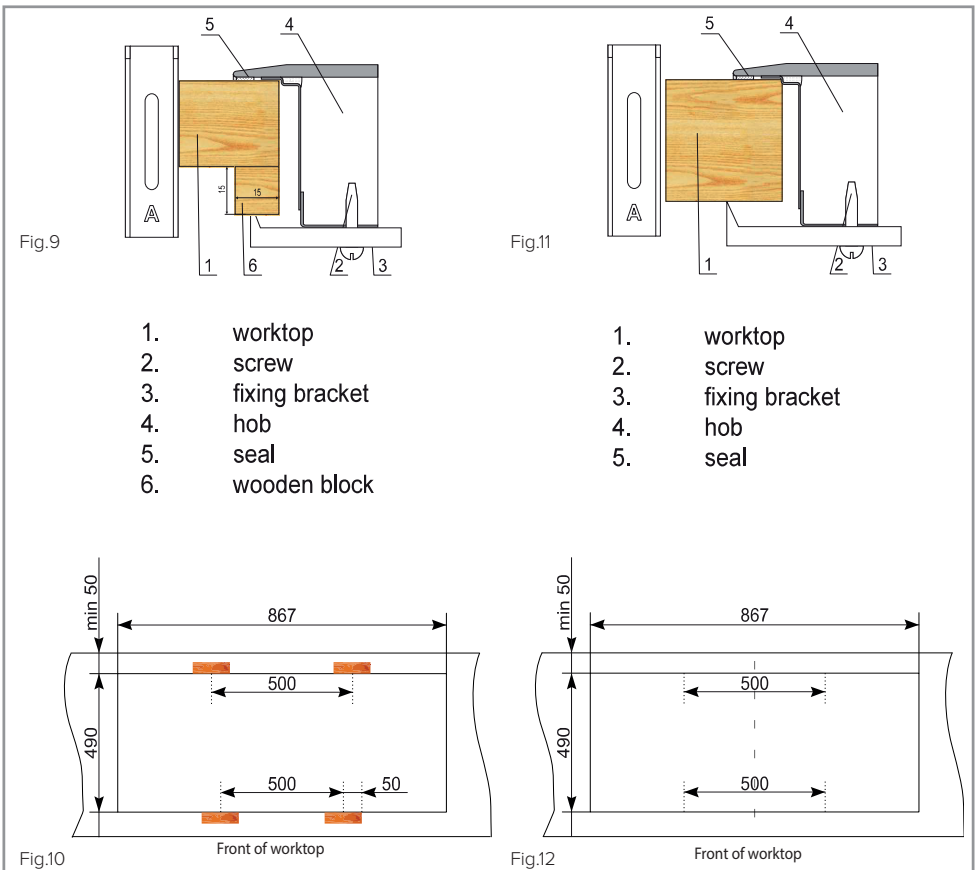

Mains electrical connection

Warning! This appliance must be earthed.

This appliance must be connected by a qualified electrician, or a similarly competent person, who is a member of the N.I.C.E.I.C. and who will comply with the I.E.T. and local regulations.

This appliance is intended to be connected to fixed wiring and is not suitable for connection to a 13A plug or 13A supply.

This appliance is intended to be connected to fixed wiring by a double pole switch, having a contact separation of at least 3mm in all poles. The switch must be positioned no further than 2m from the appliance.

Please note:

- The mains cable must only be replaced by a qualified electrician or service engineer and must be of equivalent or better rating (i.e. 4mm², HO5VV-F).
- This appliance is intended to be connected to the mains supply with a cable of cross sectional area 4mm².

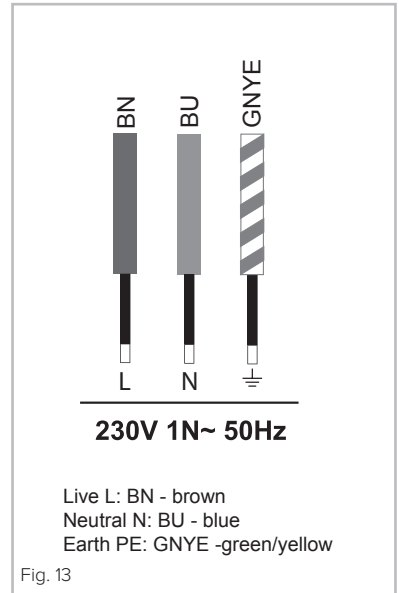

- The current rating of the fuse or circuit breaker protecting this appliance should be marked on the socket outlet.
- Assembly and electrical connection should be carried out by specialised personnel.
- When installing this product we recommend you seek the help of another individual.
- **Should the mains cable be damaged or need to be replaced, it should only be done so by a qualified electrician or engineer. The connections to the hob are shown below;**

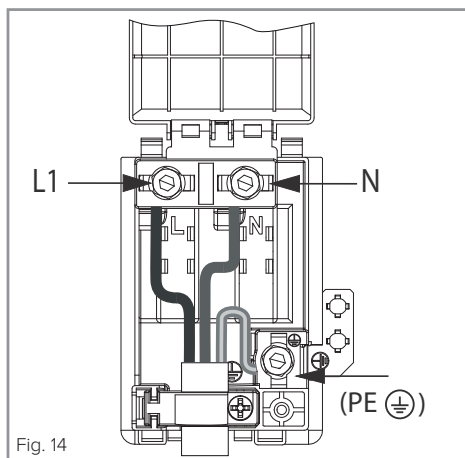

- Ensure that the leads are securely fitted. Failure to do so may prevent the hob from operating correctly.

Appliance electrical rating: 8700W

NOTES:

Energy Efficiency Information

Attribute	Symbol	Value	Units
CDA model		HC9621FR	
Type of hob		Built in	
Number of cooking zones and/or areas		5	
Heating technology (induction cooking zones and cooking areas, radiant cooking zones, solid plates)		Radiant cooking zones	
For circular cooking zones or area: diameter of useful surface area per electric heated cooking zone, rounded to the nearest 5mm	∅	FL:21.0/17.5/12.0 FR:14.5/ RL:14.5/ RR:18.0/ C:17.0x 26.5	cm
For non-circular cooking zones or areas: length and width of useful surface area per electric heated cooking zone or area, rounded to the nearest 5mm	L W	NA	cm
Energy consumption per cooking zone or area calculated per kg	EC <small>Electric cooking</small>	FL:193.5/ FR:193.5/ RL:193.5/ RR:193.5/ C:193.5	Wh/kg
Energy consumption for the hob calculated per kg	EC <small>Electric hob</small>	193.5	Wh/kg



For service or queries relating to your product please contact:

The Customer Care Department on **01949 862 012** or email customer.care@cda.eu

For more information please contact:

The Sales Department on **01949 862 010** or email sales@cda.eu

Customer Care Department. The CDA Group Ltd, Harby Road, Langar, Nottinghamshire, NG13 9HY
T: 01949 862 012 F: 01949 862 003 E: customer.care@cda.eu