



# FF151 Freestanding Under Counter Fridge With Ice Box

Manual for Installation, Use and Maintenance

# Important

The CDA Group Ltd cannot be held responsible for injuries or losses caused by incorrect use or installation of this product. Please note that CDA reserve the right to invalidate the guarantee supplied with this product following incorrect installation or misuse of the appliance.

This appliance is not designed to be used by people (including children) with reduced physical, sensorial or mental capacity, or who lack experience or knowledge about it, unless they have had supervision or instructions on how to use the appliance by someone who is responsible for their safety.

Under no circumstances should any external covers be removed for servicing or maintenance except by suitably qualified personnel.

## **Appliance information:**

Please enter the details on the appliance rating plate below for reference, to assist CDA Customer Care in the event of a fault with your appliance and to register your appliance for guarantee purposes.

|                 |  |
|-----------------|--|
| Appliance Model |  |
|-----------------|--|

|               |  |
|---------------|--|
| Serial Number |  |
|---------------|--|

## **CE Declarations of Conformity:**

This appliance has been designed, constructed and marketed in compliance with safety requirements of EEC Directive 2006/95/EEC (Low voltage) and requirements of EMC Directive 2004/108/EEC.

This appliance has been manufactured to the strictest standards and complies with all applicable legislation, including Electrical safety (LVD) and Electromagnetic interference compatibility (EMC). Parts intended to come into contact with food conform to EEC/89/109.4

## **IMPORTANT INFORMATION FOR CORRECT DISPOSAL OF THE PRODUCT IN ACCORDANCE WITH EC DIRECTIVE 2002/96/EC.**

At the end of its working life, the product must not be disposed of as urban waste. It must be taken to a special local authority differentiated waste collection centre or to a dealer providing this service.

Disposing of a household appliance separately avoids possible negative consequences for the environment and health deriving from inappropriate disposal and enables the constituent materials to be recovered to obtain significant savings in energy and resources. As a reminder of the need to dispose of household appliances separately, the product is marked with a crossed-out wheeled dustbin. 

---

## Important

Never store inflammable or explosive items and strong corrosive acids or alkalis in the appliance.

This is a household appliance, which is produced in accordance with the national standard. It is intended for food storage only, not for storage of blood, medicine and biological products.

To prevent risk of fire, keep the appliance away from petrol or any other inflammables.

To prevent risk of electromagnetic interference or other accidents, do not place a microwave oven on top of the refrigerator or use any electric appliance inside the refrigerator.

Do not allow children to play with or near the appliance.

The internal surface of freezer compartment is very cold when the appliance is running. Do not touch the surface especially with wet hands.

Do not splash water onto the appliance. Keep it away from places of high humidity that may have adverse effect on the electric insulation performance.

Please remove the door, door seal and shelves before disposal of the old appliance and put them away in a safe place to prevent children from being entrapped.

# Before First Use

**You must allow the fridge to settle for at least twenty four hours prior to switching the power on.**

It is recommended that you clean the interior of the appliance prior to first use, using a solution of bicarbonate of soda and warm water and then thoroughly drying the interior.

The fridge may have an odour to it at first use. This will disappear as the appliance cools.

**Please note:**

The appliance will work continuously until it comes down to the correct temperature.

If the appliance is switched off, you should allow five minutes before switching it on again to prevent unnecessary damage to the compressor.

Never store inflammable or explosive items and strong corrosive acids or alkalis in the appliance.

This fridge cools your food by making the inside back of the cavity cold. It is normal for frost to build up on this surface; it then dissipates and drains through a small drain at the bottom, where it evaporates harmlessly. The presence of frosting at the back is not a malfunction of the fridge.

# Setting the Temperature

**You must allow the fridge to settle for at least twenty four hours prior to switching the power on.**

- The temperature is regulated by the thermostat dial, found inside the fridge compartment on the right hand side.
- The thermostat can be adjusted between 1 (least cold) and 5 (coldest).
- To switch off the cooling system, turn the thermostat to 0.

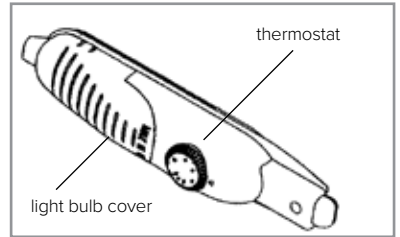

We recommend initially setting the temperature control in mid range for the first 24 hours then adjusting the temperature up or down from this point as your personal preference.

# Use

## Fridge

- Never put liquids in the refrigerator uncovered.
- Never put hot foods in the refrigerator. Warm food should be allowed to cool to room temperature before being put into the refrigerator.
- Nothing should rest against the rear wall of the refrigerator, as this will cause frost and possible condensation problems which will be difficult to remove.
- Make sure food is clean and any extra water is wiped away before putting into the fridge.
- Wrap or cover food before putting into the fridge. This will help prevent the loss of moisture, keep food fresh and avoid unpleasant odours.
- Sort foods prior to storing. Any foods to be used soon should be stored at the front of the shelf to prevent deterioration caused by the door being open for prolonged periods.
- Do not overfill the fridge. There should be sufficient space between the foods to allow the cool air to circulate.
- Thawing frozen foods in the fridge compartment will help to keep the temperature low and save energy.
- Only open the door for as long as is necessary. Leaving the door open for long periods will affect the temperature inside the appliance and waste energy.
- Ensure all compartments are fully closed after use.

# Use

## Ice Box

The ice-box door is fitted with an indicator to show whether the door is fully closed.

The door should be kept closed to prevent the contents of the ice-box defrosting, heavy build up of frost in the ice-box and excessive unnecessary use of energy.

The indicator is shown in the diagram to the right.

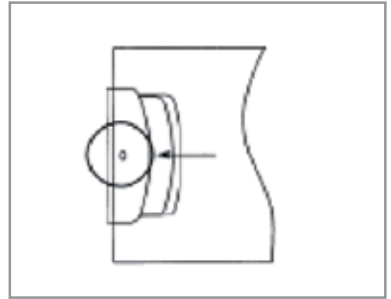

- The Door Open indicator shows red when the door is not closed properly.
- The Door Open indicator shows white when the door is fully closed.



---

## Care and Cleaning

**Always disconnect the appliance from the power supply before any cleaning or maintenance.**

The fridge sections should be cleaned using a solution of bicarbonate of soda and lukewarm water.

Do not use abrasive products or detergents. After washing, rinse and dry thoroughly.

Clean the shelves and balconies separately by hand with soap and water. Do not put them in the dishwasher.

The water drain hole at the back of the fridge compartment and the evaporating tray should be cleaned periodically to prevent the defrosted water from collecting inside the fridge compartment. The drain plug can be used to clean the drain hole.

Once cleaning is complete, then reconnect the power.

Keep the door gasket clean. If damaged, the gasket should be replaced.

If the appliance is not used for prolonged periods of time, unplug and clean the appliance. The door should be left slightly open to prevent the formation of mildew and smell.

## Defrosting the Fridge

The fridge is self-defrosting. Any water created will run out of the fridge through the channel at the back of the fridge.

It is important to keep the channel clear at all times. The defrosted water is collected in the evaporating tray at the back of the appliance.

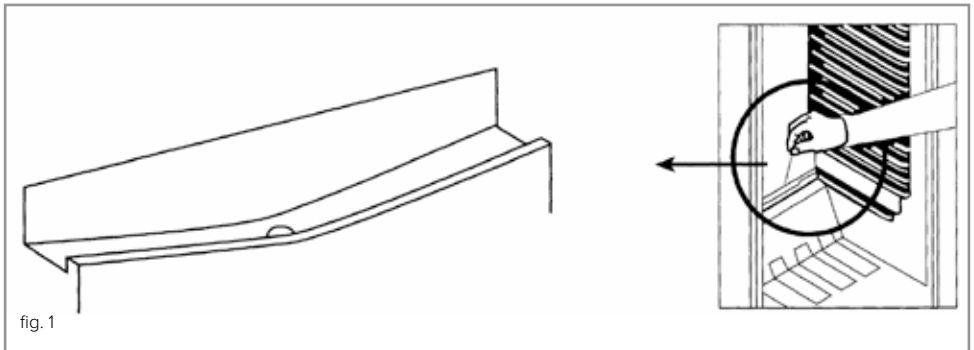

## Defrosting the Ice Box

- The ice box should be defrosted regularly to ensure the most efficient running, at a minimum of once every six months.
- Do not use heaters or defrosting sprays in this appliance.
- Never use any metallic or sharp objects to remove the ice as this could damage the lining.
- To speed up the process, put a bowl of warm water in the base of the ice-box compartment.
- Once defrosting is complete, dry the inside of the ice-box with a sponge or clean cloth.
- To bring the unit back to temperature more quickly set the thermostat to 5 after defrosting.

# Changing the Light Bulb

## **Disconnect the appliance from the power.**

- Remove the light cover by pressing the grooves on both sides of the cover and then lifting away.
- Unscrew the light bulb to remove it and replace with a new bulb (not more than 15W).
- Replace the light cover and reconnect the power after five minutes' delay as explained on page 3.

# Troubleshooting

If you have any problems with your appliance, you should check the troubleshooting prior to calling CDA Customer Care to prevent unnecessary service calls and potential cost.

## **The appliance is not working**

- Check there is power to the appliance:
- The house fuses are intact and the fuse in the plug has not blown.
- The thermostat is not set to 0 (off position).
- The plug socket is functioning fine. To check this, plug another electrical appliance in to see if the socket is working.
- The temperature of the room is adequate (16°C or above).

## **The appliance is working, but not very well**

- The appliance is not overloaded.
- The thermostat is set to an appropriate temperature.
- The door is closing properly.
- The cooling system at the rear of the appliance is clean and free of

---

dust, and not touching the rear wall.

- There is enough ventilation at the side and rear walls.
- The temperature of the room is adequate (16°C or above).

### **The appliance is noisy**

- The appliance is level and stable.
- The side and rear walls are clear, and there is nothing resting on the appliance.
- The cooling gas in the refrigerator will make a slight bubbling noise, even when the compressor is not running.

### **There is water in the lower part of the refrigerator compartment**

- The drain hole in the channel at the back of the compartment is clear.

# Reversing the Door

**It is possible to reverse the door on this appliance, if required. To do so, follow the steps below:**

1. Carefully tilt the appliance to allow access to the base of the appliance.
2. Remove the height adjustable feet.
3. Remove the lower hinge plate.
4. Lift off the door and carefully put it to one side.
5. Remove the top hinge plate. Change the hinge pin on the plate over and then replace the hinge plate on the alternate side of the door frame.
6. Remove the hinge pin receiver and blank at the top of the door and replace on the alternate side.
7. Relocate the door on the top hinge pin.
8. Refit the lower hinge plate.
9. Refit the height adjustable feet.

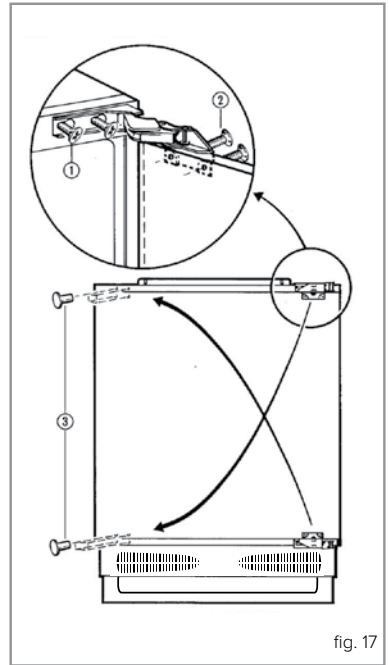
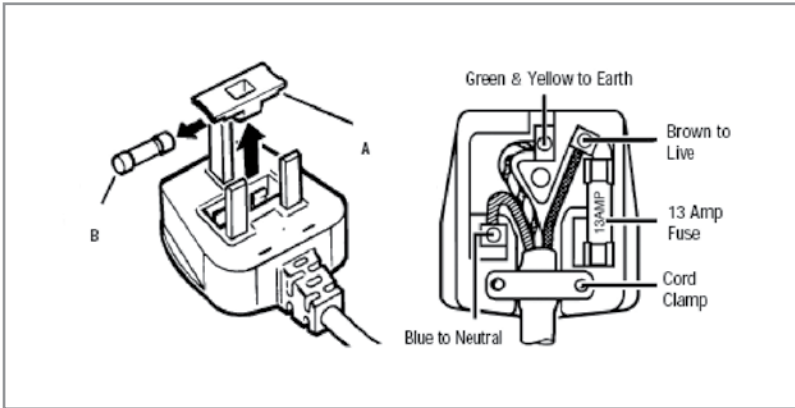

fig. 17

# Electrical Information

**Warning! This appliance must be earthed.**



The mains lead of this appliance has been fitted with a BS 1363A 13 amp fused plug. To change a fuse in this type of plug, follow the steps below:

1. Remove the fuse cover and fuse.
2. Fit replacement 13A fuse, ASTA approved to BS 1362 type, into the fuse cover.
3. Replace fuse cover.

**Important: Do not use the appliance without the fuse cover in position.**

## How to connect an alternative plug

If the fitted plug is not suitable for your socket outlet, then it should be cut off and disposed of safely to prevent the risk of electric shock. A suitable alternative plug of at least 13 Amp rating to BS 1363 should be used.

---

As the colours of the wires in the mains lead of this appliance may not correspond with the coloured markings identifying the terminals in your plug, proceed as follows:-

- The wire which is coloured GREEN and YELLOW must be connected to the terminal which is marked with letter (E) or by the Earth symbol or coloured GREEN and YELLOW.
- The wire which is coloured BLUE must be connected to the terminal which is marked with the letter (N), or coloured BLACK.
- The wire which is coloured BROWN must be connected to the terminal which is marked with the letter (L) or coloured RED.

If in doubt regarding the electrical connection of this appliance, consult a qualified electrician. Do not shorten the supply cable, the appliance may require removing for servicing.

**N.B. Ensure that the plug socket is situated in an easily accessible place.**

**If the power supply cord is damaged, it must be replaced by a CDA authorised agent.**



Please contact our Customer Care Department for Service on the details below

**Customer Care Department • The CDA Group Ltd. • Harby Road • Langar • Nottinghamshire • NG13 9HY**  
**T : 01949 862 012 F : 01949 862 003 E : [service@cda.eu](mailto:service@cda.eu) W : [www.cda.eu](http://www.cda.eu)**