

HN6840

Induction Hob

Installation, Use and Maintenance

The logo for CDA, consisting of the letters 'C', 'D', and 'A' in a bold, red, sans-serif font, each letter enclosed in a thin white vertical line, all set against a black rectangular background.

Important

The CDA Group Ltd cannot be held responsible for injuries or losses caused by incorrect use or installation of this product. Please note that CDA reserve the right to invalidate the guarantee supplied with this product following incorrect installation or misuse of the appliance or use in a commercial environment.

This appliance is not designed to be used by people (including children) with reduced physical, sensorial or mental capacity, or who lack experience or knowledge about it, unless they have had supervision or instructions on how to use the appliance by someone who is responsible for their safety.

Under no circumstances should any external covers be removed for servicing or maintenance except by suitably qualified personnel.

Appliance information:

Please enter the details on the appliance rating plate below for reference, to assist CDA Customer Care in the event of a fault with your appliance and to register your appliance for guarantee purposes.

Appliance Model	
Serial Number	

CE Declarations of Conformity

This appliance has been manufactured to the strictest standards and complies with all applicable legislation, including Electrical safety (LVD) 2006/95/EC and Electromagnetic interference compatibility (EMC)

2004/108/EC. Parts intended to come into contact with food conform to 89/109/EC.

IMPORTANT INFORMATION FOR CORRECT DISPOSAL OF THE PRODUCT IN ACCORDANCE WITH EC DIRECTIVE 2002/96/EC.

At the end of its working life, the product must be taken to a special local authority waste collection centre or to a dealer providing appliance recycling services.

Disposing of a household appliance separately avoids possible negative consequences for the environment and health. It also enables the constituent materials to be recovered, saving both energy and resources. As a reminder of the need to dispose of household appliances separately, the product is marked with a crossed-out wheeled dustbin. 

Please note:

- Induction hobs become hot and remain hot during and immediately after use. Do not touch the hob until it has been allowed to cool.
- Keep children away from the appliance when in use.
- Never use the hob top for storage.
- Pan handles should never stand out beyond the edge of the worktop. This will ensure children cannot reach them.
- Do not lean over the hob when it is in use.
- Follow the cleaning instructions carefully.
- Ensure the base of the saucepan is clean and dry before placing it on the hob.
- Avoid hard shocks from cookware – the vitroceramic glass surface is highly resistant but not unbreakable.

- Do not place hot lids flat on the hob top. A “suction” effect could cause damage to the hob.
- Do not drag cookware across the hob top: in the long term, this could cause damage to the hob.
- Do not store cleaning or flammable products in the unit below the hob.
- Always use appropriate cookware.
- Do not cook unopened tins of food directly on the hob.
- Never put cooking foil or plastic materials on the ceramic surface when the hob is hot. These materials could melt and cause damage to the hob.
- This hob (Class 3) has been designed for use only as a cooking appliance. Any other use should be considered incorrect and therefore dangerous.

FOR THOSE WITH HEART PACEMAKERS OR ACTIVE IMPLANTS:

The function of this hob conforms to current electromagnetic interference standards and thus is in total compliance with legal requirements (2004/108/CE directives).

To avoid interference between your hob and a pacemaker, your pacemaker must be designed and programmed in compliance with the regulations that apply to it. As such, CDA guarantee only that our product is compliant.

With regard to the compliance of the pacemaker or any potential incompatibility, you should obtain information from the manufacturer or your attending physician.

Important

- Do not use the hob if the glass surface is cracked or damaged to prevent the risk of electric shock. Disconnect it from the power supply.
- Ensure that the power cable of a connected electrical appliance near the hob is not in contact with the cooking zones.

Cooking On Induction

The principle of induction cooking is based on magnetic effect.

When you put your cookware on an induction zone and switch it on, the electronic boards in the hob produce induced currents in the base of the cookware and instantly raise its temperature. This heat is then transferred to the food inside the cookware.

The best cookware to use with induction cooking has thick flat bases, as the heat will be better distributed so cooking more evenly.

Most cookware is compatible with induction cooking. There are three ways to check the suitability of your cookware:

1. Use a magnet to see if the base of the pan is magnetic: if the magnet sticks, then the cookware is compatible.
2. Place the pan on one of the cooking zones switched on to power level 4: If the display remains on, then the cookware is compatible. If the display flashes, the cookware cannot be used on an induction hob.
3. Check the instructions or packaging of the pans for the symbols indicating suitability for use with induction.

Using Your Hob

Zones:

1. Front left 3.7 kW 210mm
2. Back left 3.7 kW 210mm
3. Back right 3.7 kW 210mm
4. Front right 3.7 kW 210mm

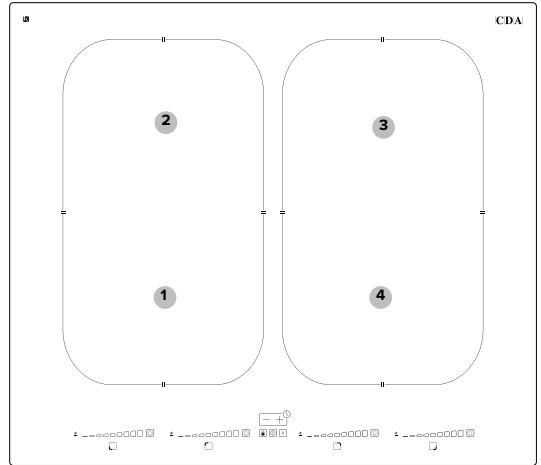

Control Panel:

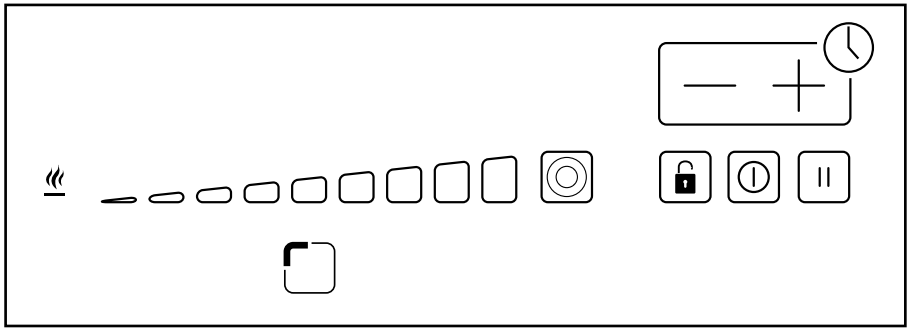

A: On/Off key

B: Key lock

C: Pause

D: Booster

E: Slider control

F: Special programmes

G: Cooking zone

H: Timer "+" key

I: Timer "-" key

Fig.1

The table below offers guidance as to what each power level is for.

Power level	Type of cooking
0	Switched off
1/2	Melting (butter/chocolate) or keeping food warm
2/3	Keeping food hot or to heat small quantities of liquid
3/4	Heat larger quantities of liquid (sauces etc.)
4/5	Slow boiling, e.g spaghetti, soups, stews, potatoes
6/7	Gentle frying
7/8	Browning meats, frying fish, omelettes
9	Fast frying steaks

Using Your Hob

To switch the hob on

To switch the power on, touch the “On/Off” key  for approximately two seconds. The hob will beep and all four zone displays will show zero.

To switch the hob off

To switch the power on, touch the “On/Off” key  for approximately two seconds

Please note: If a power level is not set within approximately ten seconds, the hob will switch off automatically.

To set the power level

There are slider keys (E) for each individual zone which allow you to set the power level by touching anywhere along them for the zone required.

To increase the power level for a zone, slide your finger along its slider (E) toward the right.

To reduce the power level for a zone, slide your finger along its slider (E) toward the left.

To turn the power off

To switch off a single zone, touch the left hand end of the slider (E) for the zone no longer required. This will set the power level to zero. When all the zones are at zero, the hob will switch off automatically after approximately ten seconds.

Alternatively, to switch off the hob immediately, touch and hold the “On/Off” key  for approximately two seconds.

Bridge function

This feature allows you to connect the front and back heating zones on the left or the right side of the hob together thus merging 2 zones into one larger one. This is particularly useful for cooking with large pans.

To set the bridge function

Touch the booster keys  for the 2 adjacent zones at the same time. The symbols “Π” and “U” will show against the power level displays for the 2 zones. The heating level of the bridged zone is controlled just by the left hand slider of the 2 connected zones.

To cancel the bridge function

Touch the booster keys  for the 2 adjacent zones at the same time.

The symbols “□” and “□” against the power level displays for the 2 zones will go out and the zones will be independently controlled again.

Pause function

When one or more heating zones is active it is possible to pause all cooking temporarily without losing the settings for the individual zones. Cooking can then be resumed at the same settings when the interruption is over. This is particularly useful when answering the phone or other interruptions while cooking.

To set the pause function

Touch the pause button . The pause LED comes on and all cooking zones turn off temporarily. They remain turned off until the pause function is cancelled.

Alternatively, if the pause function is not cancelled within ten minutes the hob will switch fully off.

To cancel the pause function

Touch the pause button , then within ten seconds touch one of the sliders. Cooking will resume at the same settings as before the pause function was activated.

Special Programmes

The hob has three optional preset programmed heating levels for each of the zones. These may be selected by touching the “Special Programmes” key  for each cooking zone. Touching this key cycles through the three programmes:-

Programme	Used For	Temperature
1	Melting	42°C
2	Warming	70°C
3	Simmering	94°C

Booster

The hob is equipped with a booster function, allowing a higher power level than the maximum for approximately ten minutes. To turn on the booster function, touch the booster key  for the zone required. “P” will show in the display. To cancel the booster at any time, touch anywhere along the slider for that zone.

Timer

The hob is equipped with a timer that allows a finish time to be set for the end of cooking on any zone, between a minimum of one minute and a maximum of 99 minutes.

To set the timer

Switch on the hob.

Set the power level for the zone requiring the timer by using its slider. Touch both the “-“ and “+” keys (together until the timer symbol shows against the slider for the required zone. The timer will display “0.00”.

Note that if more than one zone is in use, pressing the “-“ and “+” keys together several times will cycle the choice through the zones you are using.

Set the cooking duration using the “-“ or “+” key individually within five seconds. Touch and hold the “-“ or “+” key to scroll through the duration quickly.

After five seconds, the dot in the timer display will start flashing and the countdown will start. The timer display will show the minutes remaining until the last 10 minutes when it will show the seconds remaining.

At the end of the chosen time the selected zone will switch off, the timer display will flash and the hob will start to beep. To switch off the beep and the flashing display touch either the “-“ or “+” key.

To cancel the timer

Touch both the “-“ and “+” keys so the timer dot flashes, then use the “-“ or “+” key to reduce the time remaining to zero.

Please note: Cancelling the timer will not switch off the zone. You should switch off the zone manually if required.

Please note: The power level can be adjusted during the countdown using the slider for the zone being timed.

Minute Minder

To Set the Minute Minder

Switch on the hob.

Touch both the “-“ and “+” keys together until the timer symbol shows against the timer digits. The timer will display “0.00”.

Note that if any of the cooking zones is in use, pressing the “-“ and “+” keys together several times will cycle the choice through the minute minder and the zones you are using.

Set the time using the “-“ or “+” key individually within five seconds. Touch and hold the “-“ or “+” key to scroll through the duration quickly.

After five seconds, the dot in the timer display will start flashing and the minute minder countdown will start. The timer display will show the minutes remaining until the last 10 minutes when it will show the seconds remaining.

Key Lock

The hob is equipped with a key lock to lock the controls. This can be used when the hob is off or during cooking.

To switch on the key lock

Touch the key lock key  for approximately two seconds until the LED above the key lock key illuminates and the hob beeps to confirm the key lock is switched on.

To turn off the key lock

Touch the key lock key  for approximately two seconds until the LED above the key lock key switches off and the hob beeps to confirm the key lock is switched off.

Use of the key lock when the hob is in use

The key lock LED is illuminated to confirm the key lock is switched on and no adjustments can be made to any of the zones or the timer.

It is possible to switch off the hob using the On/Off key  when the key lock is on, for safety reasons.

Residual heat indicators

The hob is equipped with residual heat indicators to warn when any of the zones are still hot to the touch after cooking. An “**H**” will show in the relevant zone display after cooking until the zone is at a safe temperature to touch.

In the event of a power cut, the residual heat indicators will illuminate after the power supply is restored. However, when there is no power supply to the hob the residual heat indicators will not work, so extra care must be taken.

Please note:

You should avoid touching the zones when the hob is in use, or when an “**H**” is showing on the zone display.

Small object safety

Anything left on the control panel (e.g. cutlery or towels) will cause the hob to switch off automatically and there will be a beep every ten seconds until the obstruction is removed.

Pan detection

The hob is equipped with a sensor that will advise when the pan is

removed from the zone, or is unsuitable for use on induction hobs. The zone display will show “U” alternating with the power level until a suitable pan is placed on the zone. The zone will switch off after approximately one minute if no suitable pan is placed on the zone.

Safety cutout

The hob is equipped with a safety switch that automatically switches off zones after they have been operating for a certain period of time. The time before this is activated is dependent on the power level being used:

Power Level	Operating Time (hours)
1 - 2	6
3 - 4	5
5	4
6 - 9	1.5

Efficient Use of Your Hob

The hob is equipped with zones of different sizes, designed to accommodate most shapes and sizes of pan. For best results, only use pans with flat bottoms and choose an appropriate zone depending on the size of the pan. The most efficient use of the hob is shown below, where the pan and zone are correctly chosen.

Use pan lids where possible to minimize the energy usage of your appliance.

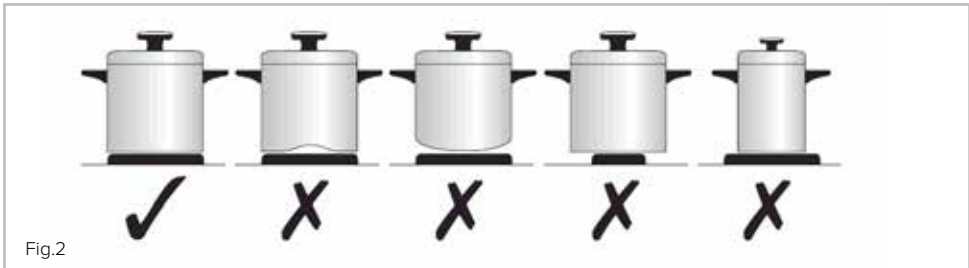

Fig.2

Zone Size	Minimum Pan Size (cm)	Maximum Pan Size (cm)
210mm	11	24

It is very important that the pans used on the hob are made of a suitable material and have the correct type of base. The base of the pan must be clean before use to prevent any scratches on the hob top.

Care and Maintenance

Always disconnect the appliance from the power supply before undertaking any cleaning or maintenance.

Important:

- Steam cleaners must not be used when cleaning this appliance. You should use a non-abrasive cleaner to clean the hob top. Any abrasive cleaner (including Cif) will scratch the surface and could erase the control panel markings.
- Sugar and starch can cause permanent damage to the surface of the hob. Wipe away any spillages immediately.

Types of residues	Clean with	Cleaning advice
Light	Cleaning sponge and soft cloth	Wipe over the zone to be cleaned with a sponge and hot water, and then wipe off with a soft dry cloth.
Accumulated baked-on stains/dirt, sugar spills or melted plastics	Cleaning sponge or glass scraper and soft cloth	Wipe over the zone to be cleaned with a sponge and hot water, using a ceramic scraper to remove any large marks or stains and then wipe off with a soft dry cloth.
Rings and hard water residues	White vinegar and soft cloth	Pour a small amount of warm white vinegar onto the stain, leave it to stand, and then wipe off with a soft dry cloth.
Shiny metallic streaks	Cleaning agent for vitroc ceramic glass etc.) Slow boiling, e.g. spaghetti, soups, stews, potatoes	Use specialist vitroc ceramic glass cleaner (preferably one with silicone for its protective properties)

If your hob is not working:

1. Check that the zone is switched on.
2. Check that the mains supply has not been switched off.
3. Check that the fuse in the spur has not blown.

In the event of a fault with the hob, please advise CDA Customer Care of any fault code shown on the display

Contact CDA Customer Care

A: Customer Care Department, The CDA Group Ltd, Harby Road,
Langar, Nottinghamshire, NG13 9HY

T: 01949 862 012 **F:** 01949 862 003

E: service@cda.eu **W:** www.cda.eu

Troubleshooting

You observe that	Possible Causes	What should you do?
The display shows a series of digits and symbols on first connection	Working normally	Nothing, the hob will be ready to use within approximately 10 seconds
Installation blows a fuse or only one side of the hob works	The electrical connection of the hob is incorrect	Check that it is set up properly (see the Electrical Connection section)
The hob produces an odour during the first cooking sessions	New appliance	Heat a saucepan full of water on each cooking zone for 30 minutes

On switching on

You observe that	Possible Causes	What should you do?
The hob does not work and the lights on the control panel do not switch on	The hob is not connected to the power supply or the power supply is faulty	Check the electrical circuit breaker and fuses
The hob is not working and the display shows a non-standard graphic	The electronics are not functioning correctly	Call CDA Customer Care
The hob is not working and the childlock LED is on	The childlock is on	Switch off the childlock before trying to use the hob.

In use

You observe that	Possible Causes	What should you do?
The saucepans make noise during cooking or your hob makes a clicking sound during cooking	This is normal with some types of cookware. This is caused by the transfer of energy from the hob to the cookware	Nothing. There is no risk, neither to your hob nor to your cookware
The fan continues to function for a few minutes after the hob is turned off	Cooling of the electronic components. Working normally	Nothing.

IMPORTANT - PLEASE NOTE: In the event of any breakage, crack or cracking – even minimal – of the vitroceramic glass, immediately disconnect your appliance to prevent a risk of electric shock and contact CDA Customer Care.

Fitting the Hob

Unpacking the hob:

Take care not to lose or mishandle any parts.

Fitting position of the hob:

This appliance must be installed a minimum of 50mm from any back wall and a minimum of 180mm away from any adjacent vertical surfaces, e.g. a tall cupboard end panel. This may be reduced to 100mm if the adjacent surface is resistant to fire (tiles or steel, for example). These dimensions are shown in Fig. 5.

Ventilation requirements:

This appliance must be installed to allow air to flow freely to the air intake, from the air outlet and in the base and run of units into which it is installed (Fig 3). An air gap of 20mm is recommended immediately below the hob.

Failure to allow sufficient ventilation could cause damage to the hob and constitutes incorrect installation, which is not covered by the warranty.

Notes:

- This could be a simple slot cut out of the plinth, or a dedicated ventilation grille.
- The furniture top rail should not be fitted to the unit. This allows the induction hob to exhaust air into the kitchen space.
- The recommended ventilation sizes are for guidance only.

If fitting a cooker hood above the hob:

If a cooker hood is to be installed above the hob, the height of

the hood above the hob must be at least 600mm (650mm is recommended) (Fig. 4). If the instructions supplied with the hood dictate that the hood must be installed at a height greater than 600mm, then that height is the minimum required.

Wall furniture requirements:

The minimum height of any cabinet immediately above the hob is 900mm. The minimum height of any adjacent units (including light pelmets) is 400mm, unless they are manufactured from a material resistant to fire (steel, for example).

Notes:

- Do not position this appliance above a refrigeration unit. The heat generated may cause the refrigeration unit to fail.
- This appliance is designed to be installed into cabinet units capable of withstanding temperatures of 65°C or greater above ambient temperature.
- Never place perishable foods, soft items such as tea towels, cleaning products or flammable items in the cupboard or drawer below the appliance.
- If an oven is to be installed below the hob, the thermal safety system on the hob will not allow the hob to be used at the same time as a pyrolytic programme on the oven.
- The hob is equipped with an anti-overheating safety device that can be activated if the hob is installed over an oven that is not sufficiently ventilated. We recommend that you increase the ventilation of the hob by creating an opening in the side of the cabinet (8cm x 5cm).

How to Install the Hob:

Overall dimensions of the hob:

Width: 580 mm Depth: 510 mm

Worktop cut-out dimensions:

Width: 560 mm Depth: 490 mm

1. Make the required hole in the worktop. Before doing this, you must check the instructions supplied with any cooker hood to ensure that you will have the required clearance. The cut-out (Fig. 5) shows a 60mm gap from the wall to the cut-out edge. The distance from the hob, when fitted, to the back wall is 50mm.

If a splashback/worktop upstand is to be fitted, take this into account when cutting the hole. The minimum distance that the hob should be positioned away from the rear wall or splashback is 50mm.

2. Fix the foam seal underneath the appliance by following the outline of the worktop upon which the hob will rest. This ensures an airtight seal with the worktop. Do not use silicone type sealant.

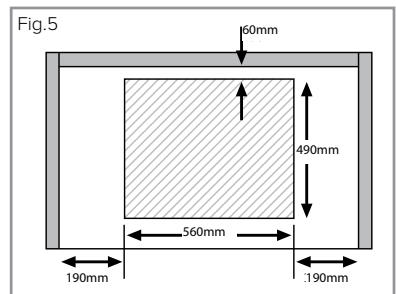
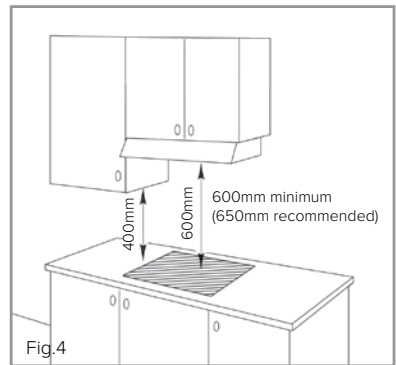
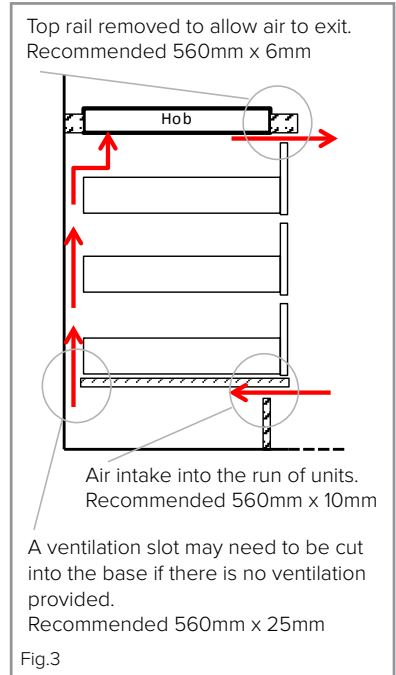

Mains Electricity Connection

Warning! this appliance must be earthed

We recommend that the appliance is connected by a qualified electrician, who is a member of the N.I.C.E.I.C. and who will comply with the I.E.T. and local regulations.

This hob is intended to be connected to permanent fixed wiring by a double pole switch, having a contact separation of at least 3mm in all poles. The switch must be positioned no further than 2m from the appliance.

Please note:

- The mains cable must only be replaced by a qualified electrician or service engineer and must be of equivalent or better rating (i.e. 2.5mm², HO5V2V2/F).
- This appliance is intended to be connected to the mains supply with a cable of cross section area 2.5 mm². A larger cable will not fit the terminal connections.
- The marking of the current rating of the fuse or circuit breaker protecting this appliance should be marked on the socket outlet.
- Assembly and electrical connection should be carried out by specialised personnel.
- When installing this product we recommend you seek the help of another individual.
- Ensure that the brass links are securely fitted. Failure to do so will prevent the hob from operating correctly.

The following diagram shows the mains connection:

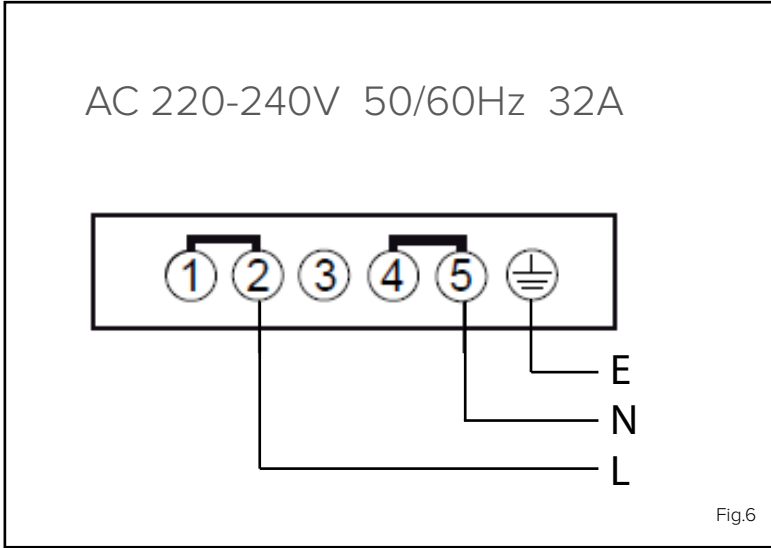

When installing this product we recommend you seek the help of another individual.

Appliance electrical rating: 7400W

Any service call arising from incorrect installation may result in a charge.

NOTES:

NOTES:

Energy Efficiency Information

Attribute	Symbol	Value	Units
CDA model		HN6840	
Type of hob		Built in	
Number of cooking zones and/or areas		4	
Heating technology (induction cooking zones and cooking areas, radiant cooking zones, solid plates)		Induction cooking zones	
For circular cooking zones or area: diameter of useful surface area per electric heated cooking zone, rounded to the nearest 5mm	∅	NA	cm
For non-circular cooking zones or areas: length and width of useful surface area per electric heated cooking zone or area, rounded to the nearest 5mm	L W	18.5 x 22.0	cm
Energy consumption per cooking zone or area calculated per kg	EC _{Electric cooking}	172	Wh/kg
Energy consumption for the hob calculated per kg	EC _{Electric hob}	172	Wh/kg

E & O E. All instructions, dimensions and illustrations are provided for guidance only. CDA reserve the right to change specifications without prior notice.



Please contact our **Customer Care Department** for Service on the details below

Customer Care Department

The ICDAI Group Ltd. • Harby Road • Langar • Nottinghamshire • NG13 9HY
T : 01949 862 012 F : 01949 862 003 E : customer.care@cda.eu

