

# 3U10 Extractor

Installation, Use and Maintenance



# Important

The CDA Group Ltd cannot be held responsible for injuries or losses caused by incorrect use or installation of this product. Please note that CDA reserve the right to invalidate the guarantee supplied with this product following incorrect installation or misuse of the appliance or use in a commercial environment.

This appliance is not designed to be used by people (including children) with reduced physical, sensorial or mental capacity, or who lack experience or knowledge about it, unless they have had supervision or instructions on how to use the appliance by someone who is responsible for their safety.

Under no circumstances should any external covers be removed for servicing or maintenance except by suitably qualified personnel.

## **Appliance information:**

Please enter the details on the appliance rating plate below for reference, to assist CDA Customer Care in the event of a fault with your appliance and to register your appliance for guarantee purposes.

Appliance Model	
-----------------	--

Serial Number	
---------------	--

## **CE Declarations of Conformity:**

This appliance has been manufactured to the strictest standards and complies with all applicable legislation, including Gas safety, Electrical safety (LVD) and Electromagnetic Interference Compatibility (EMC).

## **IMPORTANT INFORMATION FOR CORRECT DISPOSAL OF THE PRODUCT IN ACCORDANCE WITH EC DIRECTIVE 2002/96/EC.**

At the end of its working life, the product must be taken to a special local authority waste collection centre or to a dealer providing appliance recycling services.

Disposing of a household appliance separately avoids possible negative consequences for the environment and health. It also enables the constituent materials to be recovered, saving both energy and resources. As a reminder of the need to dispose of household appliances separately, the product is marked with a crossed-out wheeled dustbin .

### **Please note:**

- Under no circumstances should the extractor be connected to any gas ventilation system, flue system or hot air ducting system.
- Do not vent the extractor into an attic or loft space.
- Only install the extractor in rooms with adequate ventilation. Remember that the extractor is powerful and whatever air is extracted needs to be replaced.
- Do not tile the extractor in. It should be removable for service or maintenance.
- Do not use silicone sealant to secure the extractor to the wall.
- You must be able to isolate the extractor from the mains electrical supply after installation.

- Steam cleaners must not be used when cleaning this appliance.
- The performance of your extractor will vary depending on a number of factors, such as supply voltage and cleanliness of the filters.

**Note:**

For best performance, you should switch on the extractor 15 minutes before starting to cook and leave it to run for approximately 15 minutes after the end of cooking.

## Using Your Extractor

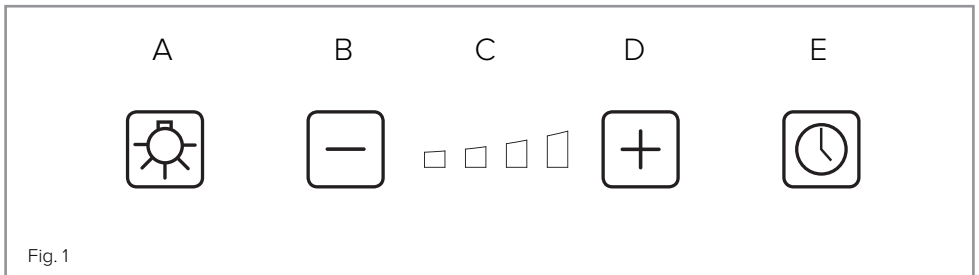

A - Light key

B - Minus key

C - Speed indicator

D - Plus key

E - Timer key

### **To switch the extractor on:**

- Touch the “Plus” key (D) to start the extractor running at the lowest speed.

### **Setting the extractor speed when it is running:**

The extractor may run at a choice of 4 speeds, indicated by the “Speed indicator” lights (C) on the control panel.

- To increase the speed touch the “Plus” key (D). The speed will increase by one increment for each touch of this key.
- To decrease the speed touch the “Minus” key (B). The speed will decrease by one increment for each touch of this key.

### **Energy saving functions:**

To help save energy:

- After 5 minutes of running at the 4th (highest) speed the motor automatically reduces to the 2nd speed.
- After 7 minutes of running at the 3rd speed the motor automatically reduces to the 2nd speed.

### **To switch the extractor off:**

- Touch the “Minus” key (B) several times to turn the extractor to its lowest speed setting, then once more to turn it off.

### **To switch the light on or off:**

- Touch the “Light” key (A).

## **The timer function:**

The timer function sets the extractor to switch itself off after ten minutes have passed. This is ideal when you leave the kitchen after cooking as the extractor can be left to clear the air then switch off to save power, without you disturbing your meal to switch it off.

- To set this function, touch the “Timer” key “E”. The “Speed indicator” will start to flash to show this function has been activated.
- To cancel this function, press either the “Plus” or “Minus” button (D) or (B).

## **Care and Maintenance**

**IMPORTANT : DO NOT PERFORM MAINTENANCE OR CLEANING OF THE EXTRACTOR WITHOUT FIRST SWITCHING OFF THE ELECTRICITY SUPPLY.**

### **Cleaning**

You should use a nonabrasive cleaner. Any abrasive cleaner (including Cif) will scratch the surface.

You can clean your extractor effectively by simply using a dilute solution of water and mild detergent and drying to a shine with a clean cloth, for example the CDA E-Cloth.

### **Cleaning the grease filters**

The grease filters should be kept clean to minimise the risk of fire.

The grease filters may be removed then cleaned with hot soapy water. You can also wash the grease filters in a dishwasher, ensuring that you place them in an upright position to prevent damage from other items in the dishwasher.

### **Please note:**

Cleaning the grease filters in the dishwasher may lead to discolouration. This is normal and does not constitute a fault with the appliance.

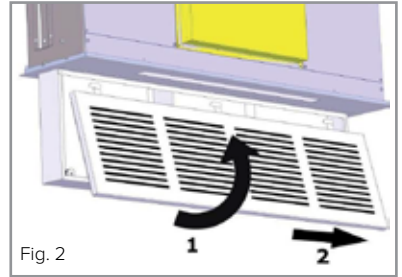

### **To remove the aluminium grease filters for cleaning**

- With the electricity supply still switched on, touch the “Plus” key once to lower the moving panel and start the motor at its lowest speed.
- Switch off the electricity supply to the extractor.
- Pull the lower edge of the filter panel toward you slightly to release it from its lower retaining magnets (Fig. 2).
- Slide the filter panel to the right to release its upper locating tabs in their slots (Fig. 2).
- Carefully lower the filter panel from the extractor.
- The grease filters may be removed from the filter panel (for cleaning) by first sliding the black plastic locating pillars aside: This releases the filters so they can be slid out.

### **To re-fit the aluminium grease filter after cleaning**

- With the electricity supply still switched off, reverse the removal process to fit the filters into the filter panel, then the panel to the extractor.
- Switch the electricity supply to the extractor back on.
- Touch the “Plus” key once to start the motor at its lowest speed.
- Touch the “Minus” key once to stop the motor and retract the moving panel back to its rest position.

## **Changing the charcoal filters (re-circulating only)**

To ensure best performance of your extractor, you should replace the charcoal filters every four to six months, depending on use.

To attach the charcoal filters:

- Remove the grease filter panel as described above.
- Position the charcoal filters in the slots at the rear of the filter panel.
- Replace the grease filter panel as described above.

**IMPORTANT: Steam cleaners must not be used to clean this appliance.**

### **If your extractor is not working:**

1. Check that the mains supply has not been switched off.
2. Check that the fuse in the spur has not blown.

### **If the speed drops without you touching a button:**

This is likely to be the energy saving feature described above: The fan speed automatically reduces from the higher speeds after a pre-set running time, to save power.

## **The LED Lamps**

The LED lamps are long-life items that are not designed to be replaced by the user. In the unlikely event of a lamp failure, contact CDA Customer Care for assistance.



# Mains Electricity Connection

**THIS APPLIANCE MUST BE CONNECTED TO THE MAINS SUPPLY BY A COMPETENT PERSON, USING FIXED WIRING VIA A DOUBLE POLE SWITCHED FUSED SPUR OUTLET AND PROTECTED BY A 3A FUSE.**

We recommend that the appliance is connected by a qualified electrician, who is a member of the N.I.C.E.I.C. and who will comply with the I.E.T. and local regulations.

The wires in the mains lead of this appliance are coloured in accordance with the following code:

**Green & Yellow = Earth**

**Blue = Neutral**

**Brown = Live**

As the colours of the wires in the mains lead for the appliance may not correspond with the coloured markings identifying the terminals connecting to the fused spur, proceed as follows:

- The wire which is coloured green and yellow must be connected to the terminal marked “E” (Earth) or coloured green.
- The wire which is coloured blue must be connected to the terminal marked “N” (Neutral) or coloured black.
- The wire which is coloured brown must be connected to the terminal marked “L” (Live) or coloured red.

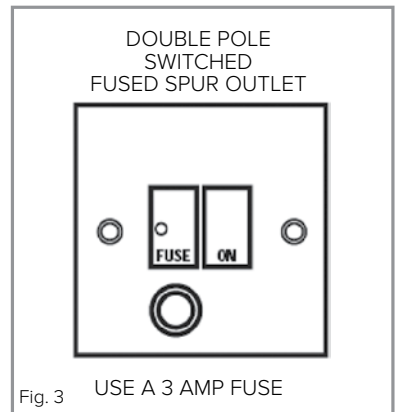

---

**Note: Use a 3A Fuse.**

Assembly and electrical connection should be carried out by specialised personnel.

When installing this product we recommend you seek the help of another individual.

Do not mount the isolation switch behind the chimney section. It is a requirement that you must be able to isolate the extractor from the mains electrical supply after installation.

This appliance is intended to be connected to the mains electrical supply by means of an isolation switch and fused spur and is intended to be protected by a 3A fuse. The use of a 13A fuse can cause damage to the internal wiring in the event of a fault, and may also invalidate the warranty.

## Electrical Information

Mains electrical voltage: 230Vac

Total rated power consumption: 90W

# Installation

When the extractor is to be installed above an electric hob, the minimum distance between the hob and extractor must exceed 650mm.

When the extractor is to be installed above a gas hob, the minimum distance between the hob and extractor must exceed 650mm.

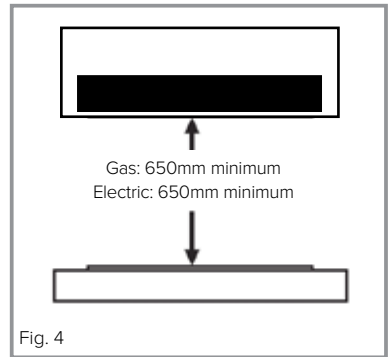

If the instructions provided with your gas hob state that the required distance between the hob and extractor must be greater than 650mm, then that is the distance that should be observed; this is a legal requirement and may lead to your hob being disconnected from the gas supply and the installation being reported to RIDDOR (The height should be measured from the top of the burners).

**IN THE ABSENCE OF ANY INSTRUCTIONS SUPPLIED WITH THE GAS HOB, THE MINIMUM DISTANCE BETWEEN THE HOB AND EXTRACTOR MUST BE AT LEAST 760mm.**

The width of any hob must not be greater than the width of the extractor installed above it.

## Ducting and Ventilation

For best performance and lowest noise output, we recommend the use of 150mm ducting. 125mm ducting may be used but this will reduce performance and increase the noise of the extractor.

# Mounting Your Extractor

**IMPORTANT:** To mount this extractor correctly onto a wall, free access to both sides of the appliance is required. This extractor is therefore unsuitable for fitting in a location where it is butting up to a side wall, fitting or other obstruction.

## To mount the extractor onto a wall:

1. Use the template supplied to mark out four fixing holes in the wall, then drill these using a suitable drill for the type of wall:
  - Two holes for the top hanging brackets.
  - Two holes toward the bottom for the lower angle brackets.

**Note:** The size required for the holes is dependent on the wall fixings to be used. The screws supplied are suitable for solid masonry walls only: Dedicated fixings (with large heads) will be required for dry lined, partition or other types of walls.

2. Insert large headed screws into the upper two mounting holes in the wall, leaving 2 - 3mm of shank protruding from the wall.
3. Attach both the hanging brackets to the body of the extractor using the smaller screws supplied (Fig. 5).

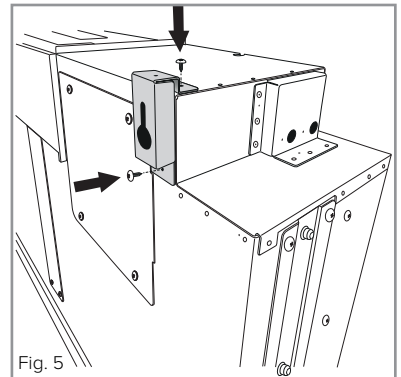

4. Attach the lower fixing brackets to the wall using large screws in the lower two holes drilled in the wall; note the correct orientation of these brackets is shown in fig. 6.

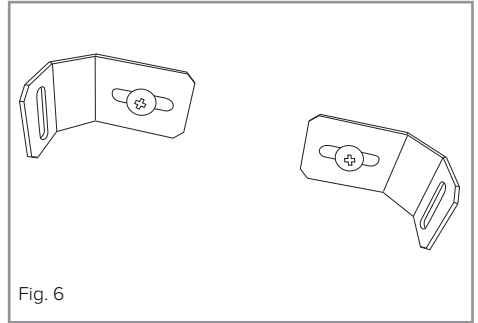

5. Only tighten the screws in these lower fixing brackets enough to hold the brackets to the wall but still allow them to be slid into their final position.

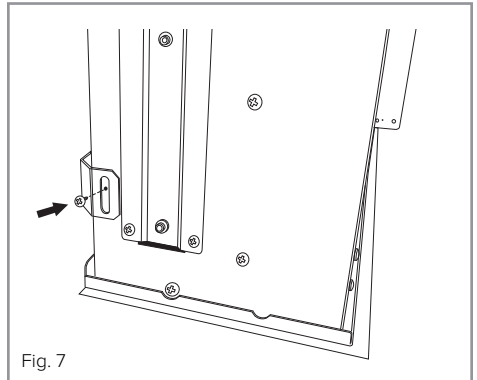

6. Lift the extractor body into position and hang it with the key-hole slots in the upper hanging brackets over the upper wall screws.

7. Insert screws through the lower fixing brackets to secure the extractor body to them (lower left one shown in Fig. 7).

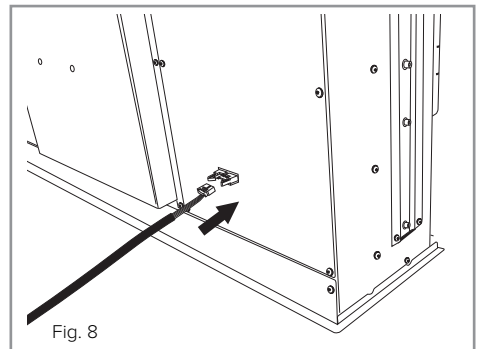

8. Mount the cover into position over the main body, ensuring that the plug on the end of the trailing lead is plugged into the socket on the front of the body unit (Fig. 8). Insert two screws into the holes in the top face to secure the cover in position.

**For recirculating installation:**

When installing for recirculation no chimney section is used.

1. Fit the mesh cover into the air outlet; this simply drops into position (Fig. 9).
2. Ensure that charcoal filters are fitted, as described in the “Care and Maintenance” section above. These are available from CDA as an accessory.

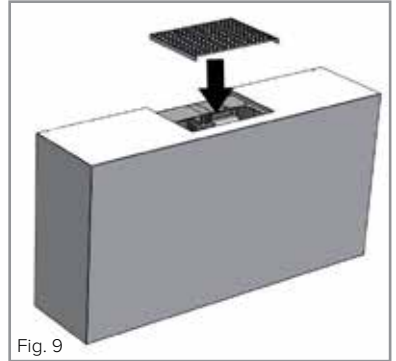

Fig. 9



### For extracting installation:

When installing for extraction both of the optional external chimney sections are often used.

1. It is usually easiest to screw the top mounting bracket ("A" in Fig. 11) to the wall and/or ceiling, centrally above the extractor outlet before assembling any ducting.
2. Fit the outlet adaptors to the body of the extractor (Fig 10). Adaptors for both round and rectangular ducting are included with the chimney.
3. Fit your choice of ducting to the outlet and route it through the ceiling or wall as required.
4. Make any necessary electrical connections within the chimney area.  
Note: the isolation switch must not be in this area, see comment under "Mains electricity connection" above.
5. The lower chimney section simply slots into the top of the extractor body.
6. Slide the upper chimney section inside the lower one then mount it to the top bracket using two self-tapping screws (Fig. 11).

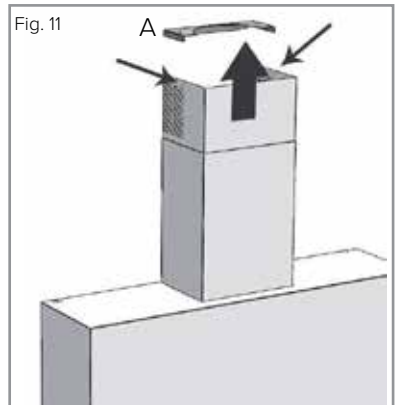

---

Notes:



---

Notes:

---

Notes:

## Energy Efficiency Information

Attribute	Symbol	Value	Units
Model Identification		3U10	
Annual Energy Consumption	$AEC_{Hood}$	46.7	kWh
Time increase factor	f	1.5	
Fluid Dynamic Efficiency	$FDE_{Hood}$	14.5 (D)	
Energy Efficiency Index	$EEl_{Hood}$	77.4	
Measured airflow at Best Efficiency Point	$Q_{BEP}$	263.7	$m^3/h$
Measured Pressure at Best Efficiency Point	$P_{BEP}$	141	Pa
Maximum airflow	$Q_{MAX}$	495.9	$m^3/h$
Measured electric power at Best Efficiency Point	$W_{BEP}$	71.3	W
Nominal lighting power	WL	10.5	W
Average illumination of the lighting system on the cooking surface	$E_{Middle}$	366	Lux
Measured power consumption in standby	$P_S$	0.49	W
Measured power consumption off mode	$P_O$	0	W
Sound power level	$L_{WA}$	68	dBA
Grease Filter Efficiency	$GFE_{Hood}$	48.4 (F)	%
Lamp efficiency	$LE_{Hood}$	34.8 (A)	%

E & O E. All instructions, dimensions and illustrations are provided for guidance only. CDA reserve the right to change specifications without prior notice.



Please contact our **Customer Care Department** for Service on the details below

**Customer Care Department**

The CDA Group Ltd. • Harby Road • Langar • Nottinghamshire • NG13 9HY

T : 01949 862 012 F : 01949 862 003 E : customer.care@cda.eu

