



# EVX110 Extractor

Installation, use and maintenance

---

## Contents:

3	Important
5	Important information
6	Using your extractor
8	Care and maintenance
9	Removing the grease filters
9	Changing/fitting the charcoal filter(s)
10 - 17	Installation
10	Installation preparation - height
12	Changing the motor position
15	Ducting
16	Ducting for recirculation mode
17	Mounting the extractor
18	Mains electricity connection
19	Electrical information
20	Troubleshooting
23	Energy Efficiency Information

# Important

The CDA Group Ltd cannot be held responsible for injuries or losses caused by incorrect use or installation of this product. Please note that CDA reserve the right to invalidate the guarantee supplied with this product following incorrect installation or misuse of the appliance or use in a commercial environment.

This appliance is not designed to be used by people (including children) with reduced physical, sensorial or mental capacity, or who lack experience or knowledge about it, unless they have had supervision or instructions on how to use the appliance by someone who is responsible for their safety.

Under no circumstances, except for instructions laid out in this manual, should any external covers be removed for servicing or maintenance except by suitably qualified personnel.

## **Appliance information:**

Please enter the details on the appliance rating plate below for reference, to assist CDA Customer Care in the event of a fault with your appliance and to register your appliance for guarantee purposes.

Appliance Model	
-----------------	--

Serial Number	
---------------	--

## **EU Declarations of Conformity:**

This appliance has been manufactured to the strictest standards and complies with all applicable legislation, including Gas safety, Electrical safety (LVD) and Electromagnetic interference compatibility (EMC).

## **IMPORTANT INFORMATION FOR CORRECT DISPOSAL OF THE PRODUCT IN ACCORDANCE WITH EC DIRECTIVE 2012/19/EU.**

At the end of its working life, the product must be taken to a special local authority waste collection centre or to a dealer providing appliance recycling services.

Disposing of a household appliance separately avoids possible negative consequences for the environment and health. It also enables the constituent materials to be recovered, saving both energy and resources. As a reminder of the need to dispose of household appliances separately, the product is marked with a crossed-out wheeled dustbin. 

**IMPORTANT:**

- Under no circumstances should the extractor be connected to any gas ventilation system, flue system or hot air ducting system.
- Do not vent the extractor into an attic or loft space.
- Only house the extractor in rooms with adequate ventilation. Remember that the extractor is powerful and whatever air is extracted needs to be replaced.
- Do not tile the extractor in. It should be removable for service or maintenance.
- Do not use silicone sealant to secure the hood to the wall.
- You must be able to isolate the extractor from the mains electrical supply after installation.
- This extractor has been designed to be used in a room with a volume of less than 36m<sup>3</sup>.
- Steam cleaners must not be used when cleaning this appliance.
- The performance of your extractor will vary depending on a number of factors. These include: type of extraction, length of ducting, room volume, ventilation available and cleanliness of the filters.
- The extractor, when extracting air, could generate a negative pressure in the room which can't exceed 0.04 mbar. Ensure that there are air intakes allowing a constant flow of fresh air within the room in which the extractor is installed. Ventilation for gas fuelled appliances must be as per regulations in force.

# Using your extractor

For best performance, you should switch on the extractor 15 minutes before starting to cook and leave it to run for approximately 15 minutes after the end of cooking (you can use the timer function for this).

1 - Speed increase button

2 - On/off button

3 - Timer button

4 - Speed decrease button

5 - Light button

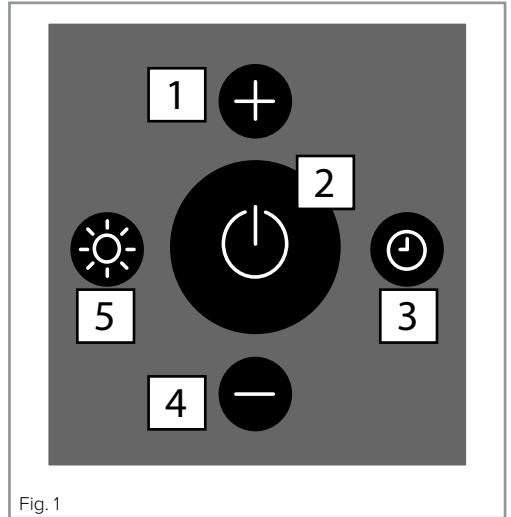

## To switch on the extractor and set the speed level

- Press button 2 on the remote. The appliance will switch on at speed level 1.
- To increase the speed level touch button 1. The LED indicator on the extractor body will change colour with each speed.
- To reduce the speed level touch button 4. **Please note** that you cannot lower the speed below speed level 2 using the remote. To return to speed 1 you must switch the extractor off and on again.
- To switch the extractor off, touch button 2.

## Intensive function

The extractor is equipped with an intensive function which runs for

approximately six minutes before returning to speed 3. This is not a fault. See page 21 for more information.

- To activate the intensive function increase the speed using the remote control until the LED indicator on the extractor turns red.
- To cancel the intensive function, press button 4 to change/lower the speed level or press button 2 to switch the extractor off.

### **Extractor lights**

- To switch the lights on and off, press button 5 on the remote control.
- The lights on this extractor are dimmable between 20% and 100% intensity. To adjust the lights, first switch them on as above. Press and hold button 5 for a maximum of approximately 5 seconds or until the desired intensity is achieved. After approximately 5 seconds the lights will be at 20% intensity.

**Please note** that the lights will be at 100% intensity each time you switch them on.

### **Timer**

The extractor is equipped with a timer that allows the extractor to run for 10 minutes before switching off automatically.

- To activate the timer, set the desired speed and press button 3. The LED indicator on the extractor body will flash to confirm the timer is active.
- To cancel the timer, press button 3 on the remote control.

**Please note** that the timer can be activated when the intensive function is on, but the intensive function will still switch to speed 3 after 6 minutes. Speed 3 will switch off after the remaining 4 minutes.

# Care and maintenance

**IMPORTANT: DO NOT PERFORM MAINTENANCE OR ATTEMPT TO CLEAN THE EXTRACTOR WITHOUT FIRST SWITCHING OFF THE ELECTRICITY SUPPLY. ALWAYS WEAR ADEQUATE PPE (PERSONAL PROTECTIVE EQUIPMENT) FOR THE TASK AT HAND.**

## Cleaning

You should use a non-abrasive cleaner. Any abrasive cleaner (including Cif) will scratch the surface and could erase the control panel markings.

You can clean your extractor effectively by simply using a dilute solution of water and mild detergent and drying to a shine with a clean cloth.

## **IMPORTANT:**

**Always protect surfaces immediately beneath the extractor (such as a hob) with clean, dry towels or similar cushioning items before carrying out any cleaning or maintenance in case of falling parts/items.**

## Cleaning the grease filters

The grease filters should be kept clean to minimise the risk of fire.

At least once a month you should remove and clean the grease filter with hot soapy water. You can also wash the grease filters in a dishwasher, ensuring that you place them in an upright position to prevent damage from other items in the dishwasher. After rinsing and drying, replace the filters. **Please note** that washing the filters in a



dishwasher can lead to discolouration. This is not a fault.

To remove the grease filters follow these steps:

1. Open the cover panel by pulling down on the LED indicator side.  
The panel will lower as far as the safety wires permit.
2. Pull down the handle on each grease filter. It will release at the handle side. Then, lower the grease filter to remove it completely.

To replace the grease filters, repeat the above steps in reverse.

### **Changing the charcoal filter (re-circulating only) - Fig. 2**

To attach a new charcoal filter, first open the cover panel and remove the grease filters as described above and any old charcoal filter(s). Then, offer up the charcoal filter to the aperture. Repeat with the other side. Then replace the grease filters and cover panels.

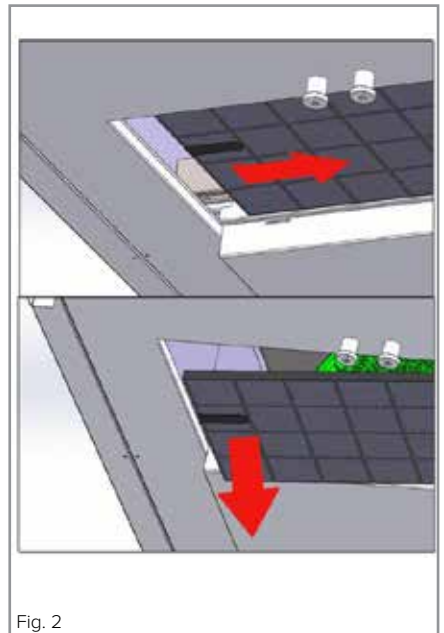

Fig. 2

This appliance is fitted with energy saving LED lighting that has a considerably longer life expectancy than traditional filament bulbs. These are not user-replaceable. In the unlikely event of a failure please contact CDA Customer Care using the details on page 21.

The lighting is designed for use during cooking and not for general room illumination. Extended use of the light can reduce the life span.

# Installation preparation

When installing this product we recommend you seek the help of at least two other individuals. This product may have some sharp edges. Please take care and wear adequate PPE (Personal Protective Equipment) when handling.

## Installation preparation - height

**IMPORTANT:** This extractor should be installed at a distance between 2000 and 2100mm from the floor in order to function properly. The fixings allow for a minimum distance of 300mm and a maximum of 480 from the solid ceiling (measured from the ceiling to the downwards-facing side of the extractor).

When the extractor is to be installed above an **electric hob**, the minimum distance between the hob and the downwards-facing side of extractor must exceed 650mm.

When the extractor is to be installed above a **CDA gas hob**, the minimum distance between the hob and the downwards-facing side of extractor must exceed 650mm.

**If the instructions provided with your gas hob state that the required distance between the hob and extractor must be greater than our measurement, then that is the distance that should be observed; this is a legal requirement and may lead to your hob being disconnected from the gas supply and the installation being reported under RIDDOR (the height should be measured from the top of the burners).**

**IN THE ABSENCE OF ANY INSTRUCTIONS SUPPLIED WITH A GAS HOB, THE MINIMUM DISTANCE BETWEEN THE HOB AND EXTRACTOR MUST BE AT LEAST 760mm. The width of a hob must not be greater than the width of the extractor installed above it.**

We **strongly recommend** fixing this appliance to a solid ceiling. It is **important** to ensure that any false ceiling does not weigh on the hood. This will help to avoid stress or strain on the extractor body. Suitable fixings must be sought if securing this extractor to joists etc.

Below (Fig. 3) is a diagram showing the overall extractor dimensions and also the dimensions between the fixing holes. This is to aid you in marking the solid ceiling in preparation for installing the extractor. If you are marking the hole positions whilst the people helping you are offering the extractor to the ceiling, we recommend removing the cover panel and the centre panel as per pages 12 and 13.

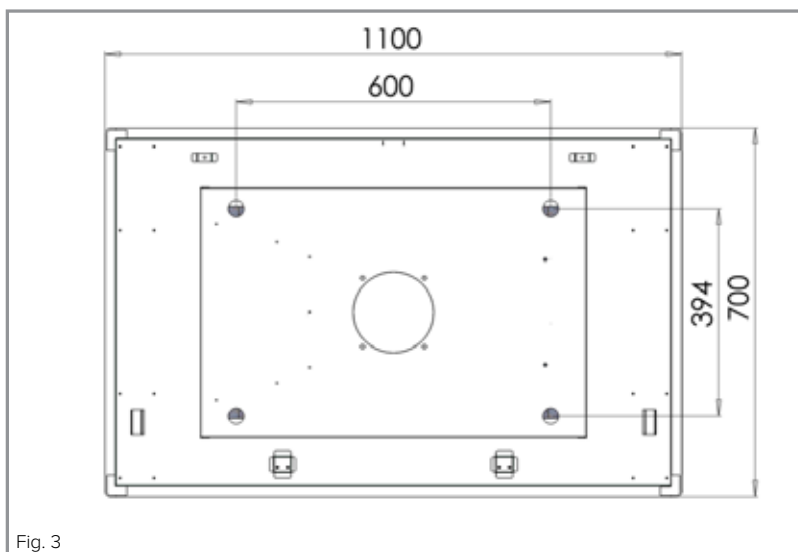

Fig. 3

**Recommended niche dimensions = 1065 x 665 mm**

### Changing the motor position:

The motor unit can be turned to position the outlet on two sides in addition to the factory standard side side. These are:

- Through the top of the motor housing (Fig. 4).
- Through the side of the motor housing as shown in Fig. 5.

**(If you do not wish to change the motor position, turn to page 15)**

The cover panel can be removed, if required, to make the installation easier. To do this, lay the extractor down on a protected surface, taking care not to damage anything. Open the cover panel most of the way and, whilst the person helping you supports the cover panel, undo the two carabiner-style clips that hold the beading wires between the cover panel and the extractor body (Fig. 6).

Open the cover panel fully but ensure that the surrounding area is cushioned or protected in case the extractor tips.

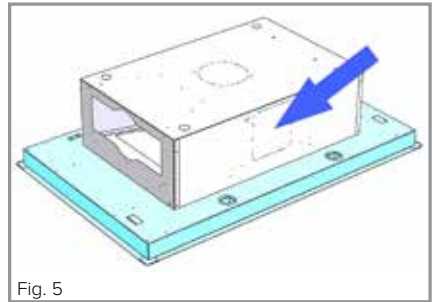
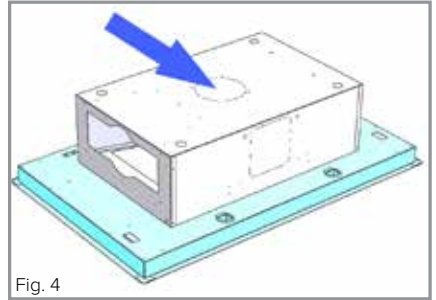

Whilst the person helping you is supporting the cover panel, undo the final carabiner-style clip on the hinge side of the cover panel and then undo the screws holding the hinges to the extractor body (Fig. 7). Place the cover panel somewhere safe where it will neither cause nor receive damage.

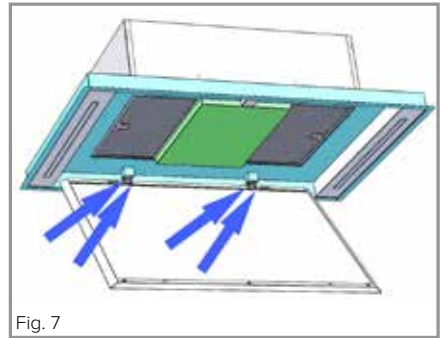

Fig. 7

Remove the four screws holding the centre panel in place (Fig. 8). Lift the centre panel clear of the extractor and place it somewhere safe (Fig. 9).

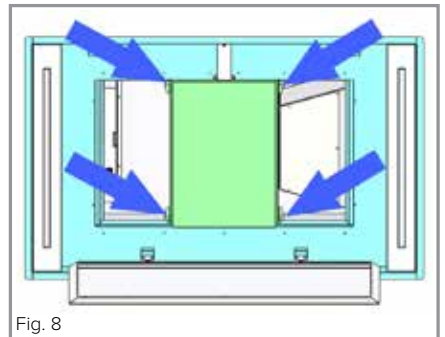

Fig. 8

Disconnect the cable connector from the motor as per Fig. 10. Remove the spot-welded plates (for the motor and the screws) from the aperture you wish to move the outlet to.

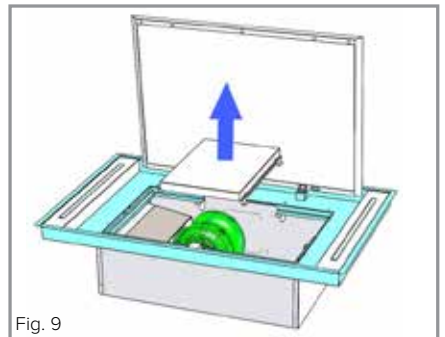

Fig. 9

Undo the four screws holding the motor in place. If you intend on moving the motor to the side wall as per Fig. 5, then you will also need to remove the motor fixing plate pictured in Fig. 11.

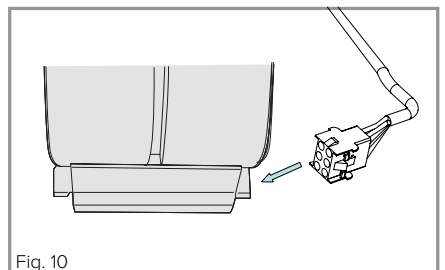

Fig. 10

Place this plate (Fig. 11) over the newly prepared area and attach with the same two screws you removed originally as per Fig. 12.

**Please note:** If you are switching the motor to the position shown in Fig. 4 then you do not need this plate.

Take the supplied cover plate and fit it over the original motor position, as per Fig. 13. Secure with two screws.

Manoeuvre the motor into its new position and attach with the four screws and washers that originally held it in place. Reconnect the cable connector, ensuring you get the connections correct (they are shaped to help).

We recommend that you now prepare the ducting. Please see pages 15 and 16 for more information.

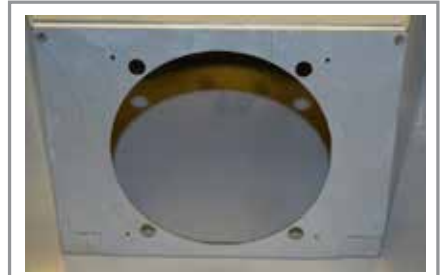

Fig. 11

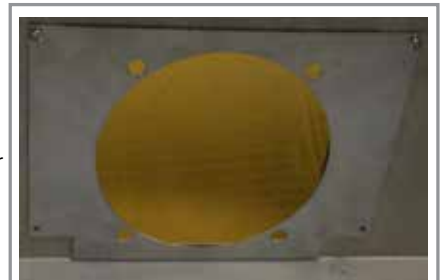

Fig. 12



Fig. 13

# Ducting

The extractor can be used as a recirculation device or as an extraction device, depending on your installation. Both types will require ducting.

The hood is more effective when used in the extraction mode (ducted to the outside). In this mode, charcoal filters are not required. The ducting used must be 150mm, rigid circular pipe and must be manufactured from fire retardant material, produced to BS 476 or DIN 4102-B1.

Wherever possible utilise rigid circular pipe which has a smooth interior, rather than the expanding concertina type ducting. The lengths of the ducting without performance being affected are as follows:

- 4 metres with 1 x 90° bend.
- 3 metres with 2 x 90° bends.
- 2 metres with 3 x 90° bends.

Longer ducting can be used but the performance of the extractor will likely be reduced.

**Please note:** Ducting components and ducting kits are optional accessories and have to be ordered, they are not automatically supplied with the hood. Use of ducting less than 150mm in diameter will affect performance and increase the noise produced by the extractor.

# Ducting for recirculation mode

An internal air vent, and ducting leading to it, is required as shown below. This ensures that the air is placed back in the kitchen/room after it has been filtered.

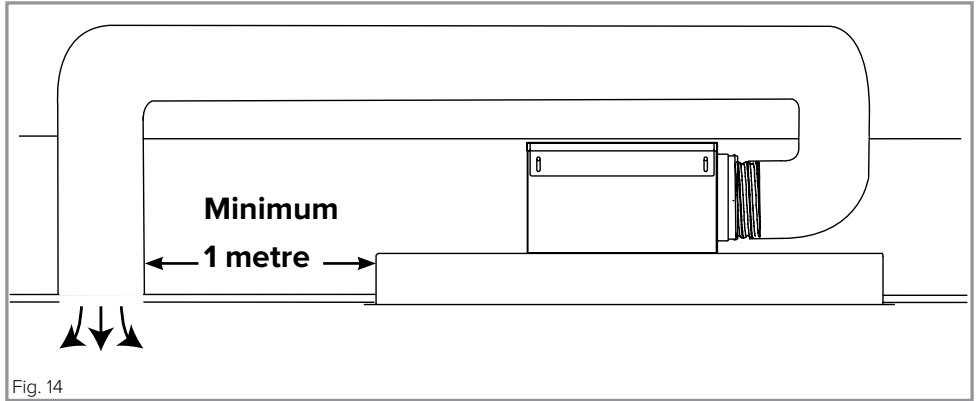

Observe the distance and bend combination as per page 15. **The vent should be at least 1 metre from the extractor** to prevent the cleansed air being drawn back into the extractor. Fit the charcoal filters to the body of the motor as shown on page 9.

Note that the duct pipe should be secured and sealed to the vent outlet pipe / valve using appropriate ducting tape or a securing clamp.

**Please note:** If you have not adjusted the position of the motor, you can remove the part of the internal housing pictured in Fig. 15 to help you secure the ducting to the motor.

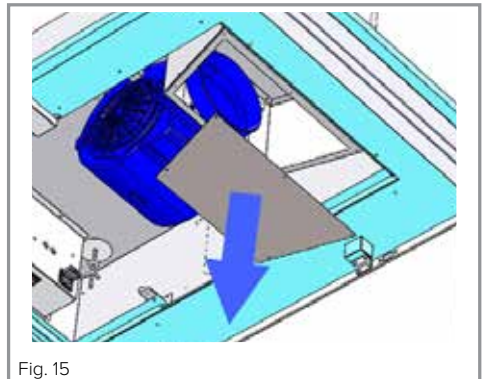



## Mounting the extractor

Once you are content with the prepared area, drill out the fixing hole markings using a  $\text{\O}10\text{mm}$  bit suitable for the solid ceiling. Remove the wingnut and two washers from each mechanical anchor. Place each anchor into the four  $\text{\O}10\text{mm}$  holes. Ensure the anchor end (A in Fig. 16) is in the solid ceiling.



Using a 10mm spanner, fully tighten the nut highlighted by the arrow in Fig. 16. This will splay the anchor within the drilled hole. Do this for each anchor.

Once you are content that the anchors are solidly secured, raise the extractor up to them and guide the pre-cut holes in the motor housing over the threaded screws. Connect the ducting and either connect or make free the electrical cable so that it can be connected to the mains later. **Do not** yet switch the power to the extractor on.

Whilst those helping you are supporting the body of the extractor, attach the washers and the wingnuts and tighten as far as they will go. Ensure the extractor is securely fastened.

Refit the centre panel, the cover panel and the grease filters.

# Mains electricity connection

**THIS APPLIANCE MUST BE CONNECTED TO THE MAINS SUPPLY BY A COMPETENT PERSON, USING FIXED WIRING VIA A DOUBLE POLE SWITCHED FUSE SPUR OUTLET AND PROTECTED BY A 3A FUSE.**

**Warning! This appliance must be earthed**

We recommend that the appliance is connected by a qualified electrician, who is a member of the N.I.C.E.I.C. and who will comply with the I.E.T. and local regulations.

The wires in the mains lead of this appliance are coloured in accordance with the following code:

**Green & Yellow = Earth**

**Blue = Neutral**

**Brown = Live.**

As the colours of the wires in the mains lead for the appliance may not correspond with the coloured markings identifying the terminals connecting to the fuse spur, proceed as follows:

- The wire which is coloured green and yellow must be connected to the terminal marked E (Earth) or coloured green.
- The wire which is coloured blue must be connected to the terminal marked N (Neutral) or coloured black.
- The wire which is coloured brown must be connected to the terminal marked L (Live) or coloured red.

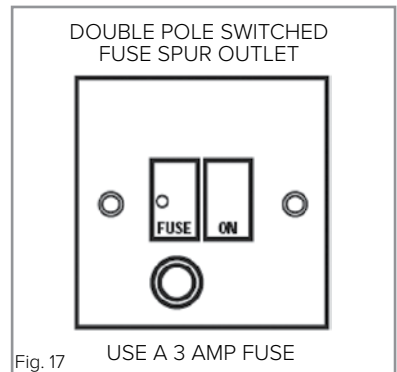

## **Note: Use a 3A Fuse**

Assembly and electrical connection should be carried out by specialised personnel.

The mains isolation switch should be readily accessible after the appliance has been installed and it is recommended that the isolation switch is located within 2m of the appliance, where practical.

This appliance is intended to be connected to the mains electrical supply by means of an isolation switch and fused spur and is intended to be protected by a 3A fuse. The use of a 13A fuse can cause damage to the internal wiring in the event of a fault, and may also invalidate the warranty.

## **Electrical information**

Mains electrical voltage: 220 – 240Vac

Total rated power consumption: 296W

# Troubleshooting

## If your extractor is not working:

1. Check that the mains supply has not been switched off.
2. Check that the fuse in the spur has not blown.
3. Check that the red power switch on the panel next to the motor has not been turned off (Fig. 18).

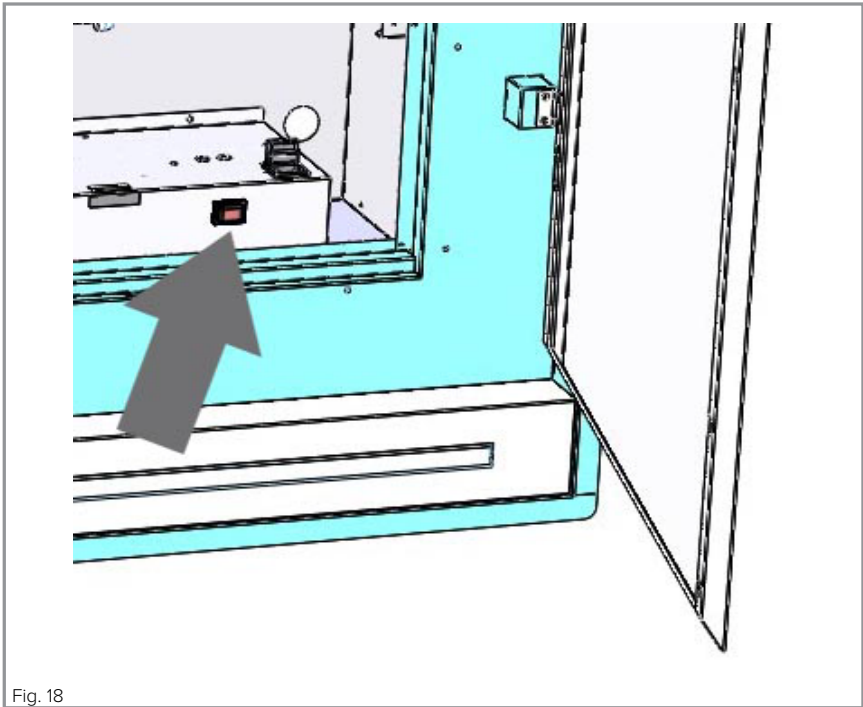

Fig. 18

## If your lights are not working:

1. Check that the mains supply has not been switched off.
2. Check whether the extractor still extracts on any speed. If not, check the fuse and power switch, as above. If the lights still do not work, contact CDA Customer Care. Contact details are on page 21.

**If you notice speed 4 reverting to speed 3 after approximately 6 minutes:**

This is not a fault. Regulations issued by the European Commission in January 2015 dictate that internal motor extractors with a maximum air capacity higher than 650m<sup>3</sup>/h must be equipped with a timer device that automatically switches the speed from '4th', or intensive, to 3rd after 6 minutes of operation.

**If the remote control is (temporarily) responding incorrectly or not at all:**

If the power supply to the extractor is cut and then restored, the appliance will run an approximately 15 second diagnostic programme. During this time the controls may not function properly.

If any of the potential resolutions in this guide do not resolve your issue, please contact CDA Customer Care using the contact details below.

**Contact CDA Customer Care**

A: Customer Care Department, The CDA Group Ltd, Harby Road,  
Langar, Nottinghamshire, NG13 9HY

T: 01949 862 012

F: 01949 862 003

E: [customer.care@cda.eu](mailto:customer.care@cda.eu)

W: [www.cda.eu](http://www.cda.eu)

---

**NOTES:**

## Energy Efficiency Information

Attribute	Symbol	Value	Units
Model Identification		EVX110	
Annual Energy Consumption	$AEC_{Hood}$	51.2	kWh
Time increase factor	$f$	0.7	
Fluid Dynamic Efficiency	$FDE_{Hood}$	35.3 (A)	
Energy Efficiency Index	$EEl_{Hood}$	49.2 (A)	
Measured airflow at Best Efficiency Point	$Q_{BEP}$	368.5	$m^3/h$
Measured Pressure at Best Efficiency Point	$P_{BEP}$	484	Pa
Maximum airflow	$Q_{MAX}$	765	$m^3/h$
Measured electric power at Best Efficiency Point	$W_{BEP}$	140.5	W
Nominal lighting power	WL	21	W
Average illumination of the lighting system on the cooking surface	$E_{Middle}$	373	Lux
Measured power consumption in standby	$P_S$	0.49	W
Measured power consumption off mode	$P_O$	0	W
Sound power level	$L_{WA}$	67	dBA
Grease Filter Efficiency	$GFE_{Hood}$	54.5 (F)	%
Lamp efficiency	$LE_{Hood}$	17.8 (C)	%

E & O E. All instructions, dimensions and illustrations are provided for guidance only. CDA reserve the right to change specifications without prior notice.



Please contact our **Customer Care Department** for Service on the details below

**Customer Care Department**

The ICDAI Group Ltd. • Harby Road • Langar • Nottinghamshire • NG13 9HY  
T : 01949 862 012 F : 01949 862 003 E : customer.care@cda.eu

