

DV 980 .. - DVT 980 .. - Double Ovens
Manual for Installation, Use and Maintenance

C|D|A

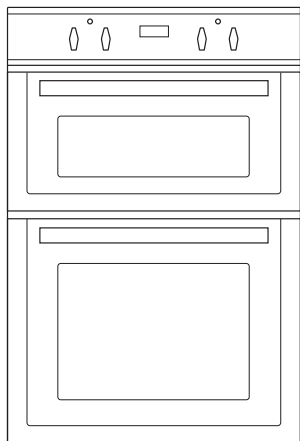

CE



Important

This appliance is designed and manufactured solely for the cooking of domestic (household) food and is not suitable for any non domestic application and therefore should not be used in a commercial environment.

The appliance guarantee will be void if the appliance is used within a non domestic environment i.e. a semi commercial, commercial or communal environment.

The CDA Group Ltd cannot be held responsible for injuries or losses caused by incorrect use or installation of this product. Please note that CDA reserve the right to invalidate the guarantee supplied with this product following incorrect installation or misuse of the appliance.

Appliance Information:

Please enter the details on the appliance rating plate below for reference, to assist CDA Customer Care in the event of a fault with your appliance and to register your appliance for guarantee purposes.

Appliance Model	<input type="text"/>
Serial Number	<input type="text"/>

Declaration of CE Conformity

This double oven has been designed, constructed and marketed in compliance with:

- Safety requirements of EU Directive "Low Voltage" 2006/95/EC;
- Protection requirements of EU Directive "EMC" 2004/108/EC;
- Requirements of EU Directive 93/68/EEC.

Important Information for Correct Disposal of the Product in Accordance with EC Directive 2002/96/EC.

At the end of its working life, the product must not be disposed of as urban waste. It must be taken to a special local authority differentiated waste collection centre or to a dealer providing this service.

Disposing of a household appliance separately avoids possible negative consequences for the environment and health deriving from inappropriate disposal and enables the constituent materials to be recovered to obtain significant savings in energy and resources. As a reminder of the need to dispose of household appliances separately, the product is marked with a crossed-out wheeled dustbin.

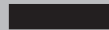

Before Using for the First Time

- Read the instructions carefully before installing and using the appliance.
- After unpacking the appliance, check that it is not damaged. In case of doubt, do not use the appliance and contact your supplier or a qualified engineer.
- Remove all the packing materials (i.e. plastic bags, polystyrene foam, etc.) and do not leave it around within easy reach of children, as these may cause serious injuries. The packaging materials are recyclable.
- Do not attempt to modify the technical characteristics of the appliance, as it may become dangerous to use.
- The appliance should be installed and all the electrical connections made by a qualified engineer in compliance with local regulations in force and following the manufacturer's instructions.

Important Precautions and Recommendations for Use of Electrical Appliances

Use of any electrical appliance implies the necessity to follow a series of fundamental rules. In particular:

- never touch the appliance with wet hands or feet;
- do not operate the appliance barefooted;
- do not allow children or disabled people to use the appliance without your supervision.

The manufacturer cannot be held responsible for any damages caused by improper, incorrect or unreasonable use of the appliance.

Using the Double Oven for the First Time

You are advised to carry out the following operations:

- Assemble the interior of the top and the lower ovens as described under the heading "Cleaning and maintenance"
- Switch the empty ovens ON at maximum temperature for about two hours to eliminate traces of grease and smell from the components.
- Let the ovens cool down, switch off the electrical supply, then clean the inside of the ovens with a cloth soaked in water and neutral detergent and dry thoroughly.

Important Safeguards and Recommendations

- Do not carry out any cleaning or maintenance without first disconnecting the appliance from the electrical supply.
- During and after use of the double oven, certain parts will become very hot. Do not touch hot parts.
- After use always ensure that the control knobs are in the **OFF** position (■ - □).
- Household appliances are not intended to be played with by children.
- Keep children away from the oven during use.
- Children, or persons with a disability which limits their ability to use the appliance, should have a responsible person to instruct them in its use. The instructor should be satisfied that they can use the appliance without danger to themselves or their surroundings.
- **WARNING**
When correctly installed, your product meets all safety requirements laid down for this type of product category. However special care should be taken around the rear or the underneath of the appliance as these areas are not designed or intended to be touched and may contain sharp or rough edges, that may cause injury.
- **Fire Risk!** Do not store inflammable materials inside the ovens.
- Always use oven gloves when removing the shelves and food trays from the oven whilst hot.
- Clean the ovens regularly and do not allow fat or oils to build up in the oven base or trays. Remove spillages as soon as they occur.
- Do not line the oven walls with aluminium foil. Do not place baking trays or the drip tray on the base of the oven chambers.
- Always stand back from the double oven when opening the oven doors to allow steam and hot air to escape before removing the food.
- Do not hang towels, dishcloths or other items on the double oven or its handles – as this could be a fire hazard.
- Make sure that electrical cords connecting other appliances in the proximity cannot become entrapped in the oven doors.
- Before disposing of an unwanted appliance, it is recommended that it is made inoperative and that all potentially hazardous parts are made harmless.
- **Important:** This appliance has been designed for domestic use only. The appliance is **NOT** suitable for use within a semi-commercial, commercial or communal environment.
- **Safe food handling:** leave food in the oven for as short a time as possible before and after cooking. This is to avoid contamination by organisms which may cause food poisoning. Take particular care during warmer weather.
- Do not operate your appliance by means of an external timer or separate remote-control system.

Control Panel

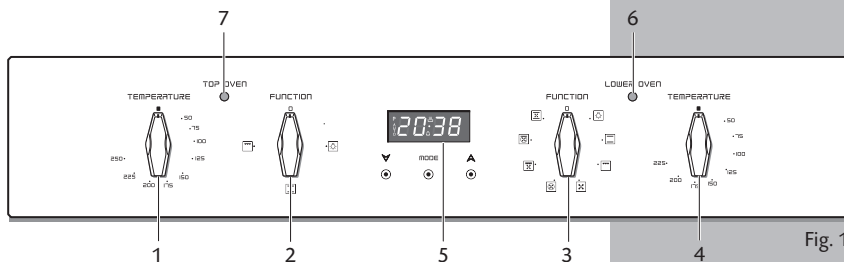

Fig. 1

Controls Description

1. Oven temperature knob (Top oven)
2. Function selector knob (Top oven)
3. Function selector knob (Lower main oven)
4. Oven temperature knob (Lower main oven)
5. Clock and timer with "Touch-Control" keys (Lower main oven only)

Warning Lights:

6. Lower main oven temperature indicator light
7. Top oven temperature indicator light

Please Note: Your appliance has been fitted with a cooling fan to achieve optimum efficiency of the controls and to ensure lower surface temperatures are maintained.

When the top oven is operating the cooling fan motor is always ON.

When only the bottom main oven is operating the cooling fan motor switches ON/OFF depending on temperature.

Depending on cooking temperatures and times, the cooling fan may run on even after appliance oven has been switched off. The duration of this time is dependent on previous cooking temperature and duration.



Top Natural Convection Oven

General Features

This oven features 2 different thermostatic control functions to satisfy all cooking requirements, provided by 3 heating elements:

- Upper element, 700 W
- Lower element, 1000 W
- Grill element, 2000 W

Note:

When using for the first time, you are advised to operate the oven at maximum temperature (thermostat knob on the maximum position) for approximately one hour in the  mode and for another 15 minutes in the  mode in order to eliminate any traces of grease from the electrical elements.

Operating Principles

Heating and cooking in the natural convection oven are obtained:

a. by Normal Convection

The heat is produced by the upper and lower heating elements.

b. by Radiation

The heat is radiated by the infra red grill element.

How to Use the Top Oven

WARNING:

The door is hot, use the handle.

ATTENTION - MOST IMPORTANT

Pay special attention not to touch the hot heating element inside the oven cavity.

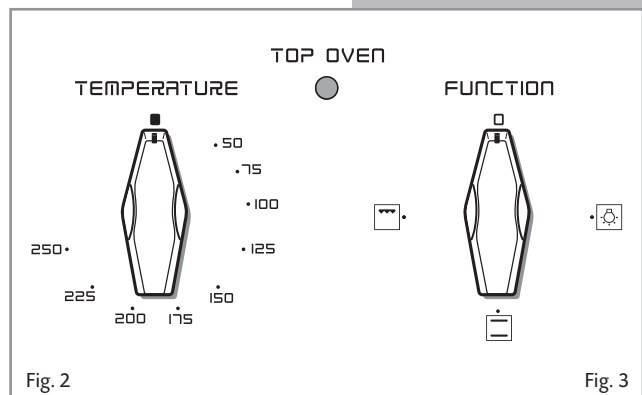
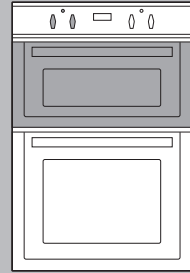

Thermostat Knob (Fig. 2)

This only sets the cooking temperature and does not switch the oven on.

Rotate clockwise until the required temperature is reached (from 50 °C to 250 °C).

The thermostat indicator light will illuminate when the oven is switched on and turns off when the oven reaches the correct temperature.

The light will cycle on and off during cooking in line with the oven temperature.

Function Selector Knob (Fig. 3)

Rotate the knob clockwise to set the oven for one of the following functions:



Oven Light

By turning the function selector knob to this setting, the oven light will illuminate in the oven cavity. The oven light will operate on all selected functions.



Traditional Convection Cooking

The upper and lower heating elements come on. The heat is dispersed by natural convection and the temperature must be set to between 50 °C and 250 °C with the thermostat knob.

The oven must be preheated before cooking.

Recommended for:

Food that requires the same degree of cooking both inside and out, for example roasts, spare pork ribs, meringues etc.



Traditional Grilling

The infrared grill element comes on. The heat is dispersed by radiation.

Use **with the oven door closed**. The temperature can be regulated via the thermostat knob to between **50 °C** and **225 °C**.

For cooking hints, see the chapter "USE OF THE GRILL".

Recommended for:

Intense grilling, browning, cooking au gratin and toasting etc.

It is recommended that you do not grill for longer than 30 minutes at any one time.

Caution: the oven door becomes very hot during operation. Keep children well out of reach.

Oven Cooking

Before introducing the food, preheat the oven to the desired temperature.

For a correct preheating operation, it is advisable to remove the tray from the oven and introduce it together with the food, when the oven has reached the desired temperature.

Check the cooking time and turn off the oven 5 minutes before the theoretical time to recuperate the stored heat.

Use of the Grill

- Preheat the oven for about 5 minutes with the door **closed**.
- Introduce the food to be cooked, positioning the rack as close to the grill as possible.
- The dripping pan should be placed under the rack to catch the cooking juices and fats.

Grilling with the oven door closed.

It is recommended that you do not grill for longer than 30 minutes at anyone time.

Attention: the oven door becomes very hot during operation.

Keep children away.

The external parts of the oven become hot during operation.

Keep children well out of reach.

Lower Main Multifunction Oven



General Features

As its name indicates, this is an oven that presents particular features from an operational point of view. In fact, it is possible to insert 7 different programmes to satisfy every cooking need.

The 7 positions, thermostatically controlled, are obtained by 4 heating elements which are:

- Bottom element 1300 W
- Top element 1000 W
- Grill element 2000 W
- Circular element 2200 W

Note:

Upon first use, it is advisable to operate the oven for 30 minutes in the position  and  to eliminate possible traces of grease on the heating elements.

Repeat the operation for another 15 minutes with the grill element on as explained in the chapters TRADITIONAL GRILLING and USE OF THE GRILL.

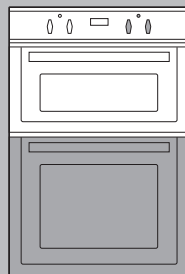

Operating Principles

Heating and cooking in the MULTI-FUNCTION oven are obtained in the following ways:

a. by Normal Convection

The heat is produced by the upper and lower heating elements.

b. by Forced Convection

A fan sucks in the air contained in the oven muffle, which sends it through the circular heating element and then sends it back through the muffle. Before the hot air is sucked back again by the fan to repeat the described cycle, it envelops the food in the oven, provoking a complete and rapid cooking.

It is possible to cook several dishes simultaneously.

c. by Semi-Forced Convection

The heat produced by the upper and lower heating elements is distributed throughout the oven by the fan.

d. by Radiation

The heat is radiated by the infra red grill element.

e. by Radiation and Ventilation

The irradiated heat from the infra red grill element is distributed throughout the oven by the fan.

f. by Ventilation

The food is defrosted by using the fan only function without heat.

How to Use the Lower Main Oven

WARNING:

The door is hot, use the handle.

ATTENTION -

MOST IMPORTANT

Pay special attention not to touch the hot heating element inside the oven cavity.

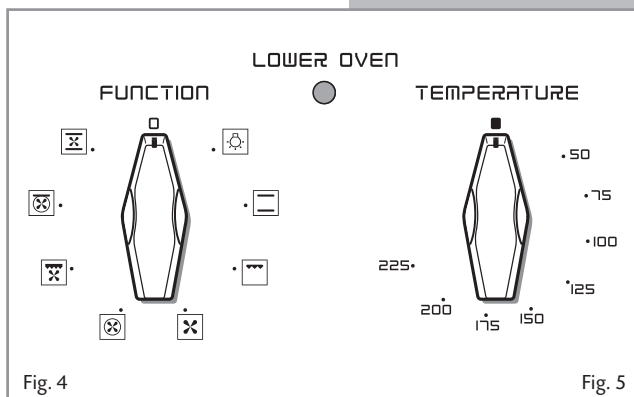

Thermostat Knob (Fig. 5)

This only sets the cooking temperature and does not switch the oven on.

Rotate clockwise until the required temperature is reached (from 50 °C to 225 °C).

The thermostat indicator light will illuminate when the oven is switched on and turns off when the oven reaches the correct temperature.

The light will cycle on and off during cooking in line with the oven temperature.

Function Selector Knob (Fig. 4)

Rotate the knob clockwise to set the oven for one of the following functions:



Oven Light

By turning the function selector knob to this setting, the oven light will illuminate in the oven cavity. The oven light will operate on all selected functions.



Traditional Convection Cooking

The upper and lower heating elements come on. The heat is dispersed by natural convection and the temperature must be set to between 50 °C and 225 °C with the thermostat knob.

The oven must be preheated before cooking.

Recommended for:

Food that requires the same degree of cooking both inside and out, for example roasts, spare pork ribs, meringues etc.



Traditional Grilling

The infrared grill element comes on. The heat is dispersed by radiation.

Use **with the oven door closed**. The temperature can be regulated via the thermostat knob to between **50 °C** and **225 °C**.

For cooking hints, see the chapter "USE OF THE GRILL".

Recommended for:

Intense grilling, browning, cooking au gratin and toasting etc.

It is recommended that you do not grill for longer than 30 minutes at any one time.

Caution: the oven door becomes very hot during operation. Keep children well out of reach.



Defrosting Frozen Foods

Only the oven fan comes on. Use with the thermostat knob set to "■" - other positions have no effect. The food is thawed by ventilation without heating.

Recommended for:

Quick thawing of frozen foods; one kg requires approximately 1 hour.

Thawing times vary according to the quantity and type of food to be thawed.



Hot Air Cooking

The circular element and fan come on. The heat is dispersed by forced convection and the temperature can be regulated to between 50 °C and 225 °C via the thermostat knob. The oven does not require preheating.

Recommended for:

Food which has to be well-cooked outside and soft or rosy inside, for example lasagne, lamb, roast beef, whole fish etc.



Ventilated Grill Cooking

The infrared grill element and the fan come on. The heat is dispersed mainly by radiation and the fan then distributes it all over the oven.

Use with the oven door closed. The temperature can be regulated via the thermostat knob to **between 50 °C and 200 °C**.

The oven must be preheated for approximately 5 minutes. For cooking hints, see the chapter "GRILLING AND AU GRATIN."

Recommended for:

Grilling where quick browning on the outside is required to keep the juices in.

For example: veal steaks, chops, hamburgers etc.

It is recommended that you do not grill for longer than 30 minutes at any one time.

Caution: the oven door becomes very hot during operation. Keep children well out of reach.



Maintaining Temperature After Cooking or Slowly Heating Foods

The upper heating element, the circular element and the fan come on.

The heat is dispersed by forced convection with greater intensity in the upper part.

The temperature can be set to between 50 °C and 140 °C via the thermostat knob.

Recommended for:

Keeping food warm after any type of cooking. Slow heating of cooked food.



Convection Cooking with Ventilation

The upper and lower heating elements come on and the fan.

The heat coming from above and below is dispersed by convection with ventilation.

The temperature can be set to between 50 °C and 225 °C via the thermostat knob.

Recommended for:

Voluminous dishes and large quantities which require the same degree of cooking both inside and out, for example rolled roasts, turkey, roast legs, cakes etc.

Cooking Advice

Sterilization

Sterilization of foods to be conserved, in full and hermetically sealed jars, is done in the following way:

- Set the switch to position .
- Set the thermostat knob to position 185 °C and preheat the oven.
- Fill the dripping pan with hot water.
- Set the jars onto the dripping pan making sure they do not touch each other and the door and set the thermostat knob to position 135 °C.



When sterilization has begun, that is, when the contents of the jars start to bubble, turn off the oven and let cool.

Regeneration

Set the switch to position  and the thermostat knob to position 150 °C.

Bread becomes fragrant again if wet with a few drops of water and put into the oven for about 10 minutes at the highest temperature.

Simultaneous Cooking of Different Foods

With the function selector in position  and  the ventilated oven allows you to cook different types of food at the same time.

Fish, cakes and meat can be cooked together without the smells and flavours mixing.

The only precautions required are the following:

- The cooking temperatures must be as close as possible with a maximum difference of 20 - 25 °C between the different foods.
- Different dishes must be placed in the oven at different times according to the cooking time required for each one. This type of cooking obviously provides a considerable saving on time and energy.

Grilling and "Au Gratin"

Grilling may be done by selecting grill+fan setting  with the function selector knob, because the hot air completely envelops the food that is to be cooked.

After having preheated the oven, simply place the food on the grid.

Close the door and let the oven operate until grilling is done.

Adding a few dabs of butter before the end of the cooking time gives the golden "Au Gratin" effect.

Grilling with the oven door closed.

It is recommended that you do not grill for longer than 30 minutes at any one time.

Caution: the oven door becomes very hot during operation. Keep children well out of reach.

Roasting

To obtain classical roasting, it is necessary to remember:

- that it is advisable to maintain a temperature between 180 °C and 200 °C.
- that the cooking time depends on the quantity and the type of foods.

Use of the Grill

- Preheat the oven for about 5 minutes with the door **closed**.
- Introduce the food to be cooked, positioning the rack as close to the grill as possible.
- The dripping pan should be placed under the rack to catch the cooking juices and fats.

Grilling with the oven door closed.

It is recommended that you do not grill for longer than 30 minutes at anyone time.

Attention: the oven door becomes very hot during operation.

Keep children away.

The external parts of the oven become hot during operation.

Keep children well out of reach.

Clock and Timer with "Touch-Control" Keys (Lower Main Oven only)

Keys

- ▲ and ▼ Touched simultaneously (for more than 2 seconds):
- setting the clock;
 - setting the timer volume (by touching once, along with the "MODE" key);
 - to cancel automatic cooking at any time.

- MODE Function selection (touched for more than 2 seconds):
- setting the clock (only after first connection or after a power failure);
 - timer;
 - automatic cooking "dur" (duration) - how long the food will take to cook (by touching the "MODE" key again);
 - automatic cooking "End" - the time you would like the oven turns off (by touching the "MODE" key two more times);

- ▲ Increases the number shown on the display
- ▼ Decreases the number shown on the display

Illuminated Symbols:

- AUTO** *flashing* - Automatic cooking completed, oven in automatic position but not set
- AUTO** *steady illumination* - Oven set for automatic cooking, cooking still not taking place
- "▲" *flashing* - Timer being set
- "▲" *steady illumination* - Timer in operation
- "☰" *steady illumination* - Oven set for manual cooking
- "☰" and **AUTO** *AUTO flashing* - Automatic cooking being set
- "☰" and **AUTO** *steady illumination* - Oven set for automatic cooking, cooking taking place.

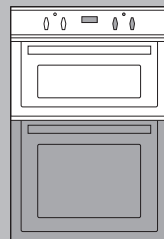

Fig. 6

"Touch-Control" Keys

The "touch-control" keys shall be operated by the fingers (just by touching the key). When using touch controls it is best to use the ball of your finger rather than the tip.

The keys are automatically deactivated:

– 8 seconds after the last selection; the deactivation is indicated by an acoustic signal ("beep").

To reactivate just touch the "MODE" key or the "▲" and "▼" keys.

Setting the Clock

When first connected, or after a power failure, the digits and "AUTO" will shown on the display. To set the clock, touch the "MODE" key, for more than 2 seconds, and then the "▲" or "▼" keys.

Important: The oven does not operate, in manual cooking, without first having set the clock.

To set the clock, with the appliance already connected, touch the "▲" and "▼" keys simultaneously (for more than 2 seconds), then "▲" or "▼" keys.

Important: - changing the time will delete any automatic program;

– after setting the clock, the oven starts to operate in the selected function (manual cooking).

The "🕒" symbol is steady illuminated.

Using the Timer

You can use the timer at any time, even when the oven is not in use. The timer does not turn the oven off.

The timer can be set for up to 23 hours and 59 minutes.

– To set the timer, touch the "MODE" key for more than 2 seconds (the "🕒" symbol flashes), than the "▲" or "▼" keys.

– After about 8 seconds an acoustic signal ("beep") will sound confirming the regulation ("🕒" symbol steady illuminated).

– To check the remaining time touch the "MODE" key for more than 2 seconds. If the remaining time is more than a minute the display will show hours and minutes; if less than a minute the display will show seconds.

– When the time is up, the timer will beep. Touch the "MODE" key, for more then 2 seconds, to turn it off; or press the "▲" or "▼" key to stop the beep and than the "MODE" key, for more than 2 seconds, to deactivate the "🕒" symbol flashing on the display.

– Turn off the oven manually (function and thermostat knobs in the off position) if the manual cooking has been completed.

Setting the Timer Volume

You can select from three volume levels.

– Touch the "▲" and "▼" keys simultaneously for more than 2 seconds.

– Touch the "MODE" key; you can read on the display the current timer volume ("ton1", "ton2" or "ton3").

– Touch the "▼" key to listen or change the timer volume.

– Timer volume activated: the last displayed.

– After about 8 seconds an acoustic signal ("beep") will sound confirming the volume setting; then the time of day will be displayed.

Automatic Cooking

Use automatic cooking to automatically turn the oven on, cook, and then turn the oven off.

1. Check the clock shows the correct time.
2. Select the function and temperature (function and temperature knobs). The oven will come on.
3. Decide how long the food will take to cook, allowing time for preheating if necessary.
4. Touch the "MODE" key for more than 2 seconds and then touch again. "dur" will show (duration). Using the "▲" and "▼" keys, set the cooking time.
5. Decide the time you would like the oven to turn off; touch the "MODE" key for more than 2 seconds and then touch it two times again. "End" will show. Using the "▲" and "▼" keys, set the cooking time.

Note: While "dur" is displayed you can change to "End" just by touching one time the "MODE" key (within 8 seconds from the last selection).

If there is time to wait before cooking starts, the current time of day and "AUTO" will show in the clock display. The oven will switch off but is now set for automatic cooking.

If you are already at home to turn the oven on and only want the oven to turn off automatically, start cooking as normal, then follow step 4 or step 5 to set a time to stop the oven.

When automatic cooking starts, "🔥" will be displayed and the oven will turn on.

- To see the remaining cook time, follow step 4 up to display "dur" (duration).
- To see the set stop time, follow step 5 up to display "End".
- To cancel automatic cooking at any time, touch the "▲" and "▼" keys simultaneously (for more than 2 seconds) and turn the temperature and function knobs to the off position.

When the stop time is reached, the oven will turn off, the timer will beep and "AUTO" will flash:

- Touch any key to stop the beeping.
- Touch the "MODE" key, for more than 2 seconds, to return the oven to the manual mode ("🔥" symbol steady illuminated on the display).
- Turn the temperature and function knobs to the off position.

Attention: After a power failure any automatic program is deleted. Turn off the oven manually.

Do's and do not's

- Do always grill with the oven door closed.
- Do read the user instructions carefully before using the double oven for the first time.
- Do allow the double oven to heat for one and a half hours, before using for the first time, in order to expel any smell from the new oven insulation, without the introduction of food.
- Do clean your double oven regularly.
- Do remove spills as soon as they occur.
- Do always use oven gloves when removing food shelves and trays from the ovens.
- Do not allow children near the double oven when in use.
- Do not allow fat or oils to build up in the oven trays, or oven base.
- Do not place cooking utensils or plates directly onto the oven base.
- Do not grill food containing fat without using the grid.
- Do not cover the grilling grid with aluminium-foil.
- Do not use the oven tray for roasting.
- Do not place hot enamel parts in water. Leave them to cool first.
- Do not allow vinegar, coffee, milk, saltwater, lemon or tomato juice to remain in contact with enamel parts (inside the oven and on the oven tray).
- Do not use abrasive cleaners or powders that will scratch the surfaces and the enamel.
- Do not attempt to repair the internal workings of your oven.
- Do remove the protective film before the first use.
- **Fire risk!** Do not store flammable material in the ovens.

For Your Safety

The product should only be used for its intended purpose which is for the cooking of domestic foodstuffs.

Under no circumstances should any external covers be removed for servicing or maintenance except by suitably qualified personnel.

Important Notes

Installation, and any demonstration, information or adjustments are not included in the warranty.

The oven must be installed by a suitably qualified and registered person in accordance with the relevant Standards.

ATTENTION:
The appliance gets very hot, mainly around the cooking areas. It is very important that children are not left alone in the kitchen when you are cooking.

Care and Maintenance

It is advisable to clean when the appliance is cold and especially for cleaning the enamelled parts.

Avoid leaving alkaline or acidic substances (lemon juice, vinegar, etc.) on the surfaces.

Avoid using cleaning products with a chlorine or acidic base.

WARNING

When correctly installed, your product meets all safety requirements laid down for this type of product category. However special care should be taken around the rear or the underneath of the appliance as these areas are not designed or intended to be touched and may contain sharp or rough edges, that may cause injury.

Inside of Oven

The oven should always be cleaned after use when it has cooled down.

The cavity should be cleaned using a mild detergent solution and warm water. Suitable proprietary chemical cleaners may be used after first consulting with the manufacturers recommendations and testing a small sample of the oven cavity. Abrasive cleaning agents or scouring pads/cloths should not be used on the cavity surface.

NOTE: The manufacturers of this appliance will accept no responsibility for damage caused by chemical or abrasive cleaning.

Enamelled Parts

All the enamelled parts must be cleaned with a sponge and soapy water only or other non-abrasive products.

Dry preferably with a micro fibre or soft cloth.

Stainless Steel, Aluminium, Painted Parts and Silk-screen Printed Surfaces

Clean using an appropriate product. Always dry thoroughly.

Stainless steel surfaces: can be cleaned with an appropriate stainless steel cleaner.

IMPORTANT: these parts must be cleaned very carefully to avoid scratching and abrasion. You are advised to use a soft cloth and neutral soap.

Glass Control Panel

Clean using an appropriate product. Always dry thoroughly.

Do not use harsh abrasive cleaners or sharp metal scrapers to clean the control panel since they can scratch the surface, which may result in shattering of the glass.

IMPORTANT:

Before any operation of cleaning and maintenance disconnect the appliance from the electrical supply.

ATTENTION:

Let the oven cool down and pay special attention no to touch the hot heating elements inside the oven cavity.

CAUTION:

Do not use abrasive substances or non-neutral detergents as these will irreparably damage the surface.

CAUTION:

Do not use a steam cleaner because the moisture can get into the appliance thus make it unsafe.

CAUTION:

Do not store flammable material in the oven.

CAUTION:

Do not use harsh abrasive cleaners or sharp metal scrapers to clean the oven door glass since they can scratch the surface, which may result in shattering of the glass.

Replacing the Halogen Oven Lights

WARNING: Ensure the appliance is switched off before replacing the lamp to avoid the possibility of electric shock.

- Let the oven cavity and the heating elements to cool down;
- Switch off the electrical supply;
- Remove the protective cover **C** (fig. 7);
- Replace the halogen lamp **B** with a new one suitable for high temperatures having the following specifications: 230V and same power (check watt power as stamped in the lamp itself) of the replaced lamp.

IMPORTANT WARNING: Never replace the bulb with bare hands; contamination from your fingers can cause premature failure. Always use a clean cloth or gloves.

- Refit the protective cover;

Note: Oven bulb replacement is not covered by your guarantee.



WRONG

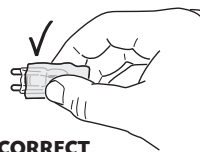

CORRECT

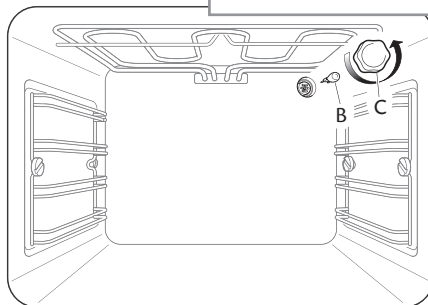
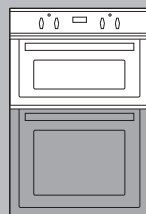
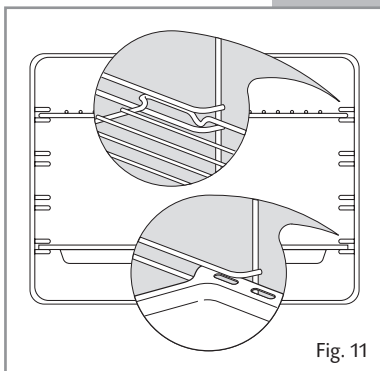
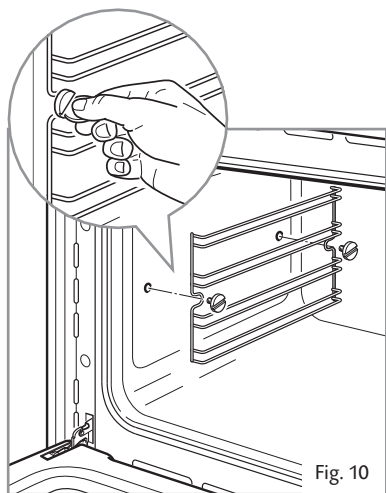
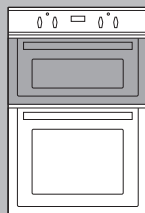
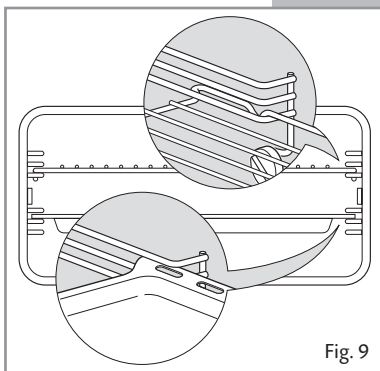
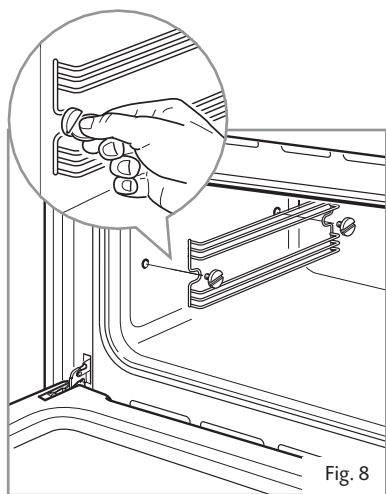

Fig. 7

Assembling and Dismantling of the Side Runner Frames

- Assemble the wire racks to the oven walls using the 2 screws (Figs. 8-10).
- Slide the tray and rack into the runners (Figs. 9-11). The rack must be fitted so that the safety catch, which stops it sliding out, faces the inside of the oven.
- To dismantle, operate in reverse order.



Oven Doors

Removing the Oven Doors

The oven doors can easily be removed as follows:

- Open the door to the full extent (fig. 12a).
 - Open the lever **A** completely on the left and right hinges (fig. 12b).
 - Hold the door as shown in fig. 12.
 - Gently close the door (fig. 12c) until left and right hinge levers **A** are hooked to part **B** of the door (fig. 12b).
 - Withdraw the hinge hooks from their location following arrow **C** (fig. 12d).
 - Rest the door on a soft surface.
- To replace the door, repeat the above steps in reverse order.

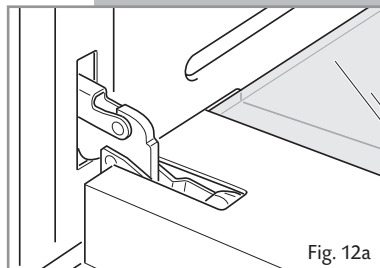
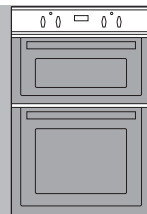

Fig. 12a

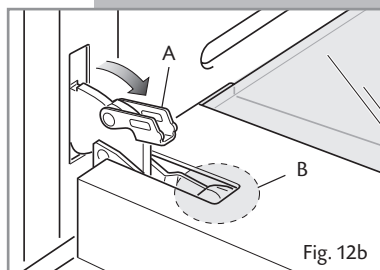

Fig. 12b

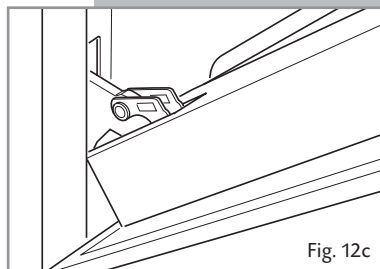

Fig. 12c

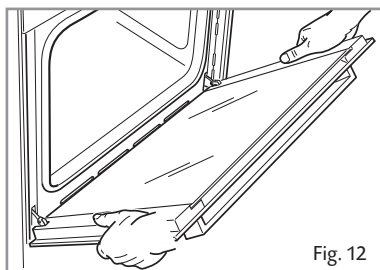

Fig. 12

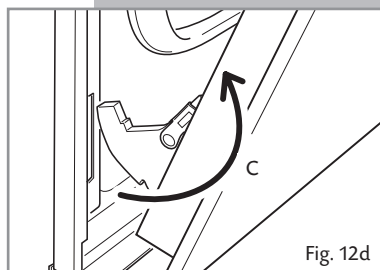

Fig. 12d

Oven Doors - Removable Inner Pane of Glass

Cleaning the Panes of Glass

The oven doors are fitted with no. 2 panes:

- no. 1 outside;
- no. 1 inner;

To clean the panes on both sides it is necessary to remove the inner pane as follows.

Do not use harsh abrasive cleaners or sharp metal scrapers to clean the oven door glass since they scratch the surface, which may result in shattering of the glass.

Removing the Inner Pane of Glass

The oven door has two panes. To clean these, you need to remove the inner pane.

1. Lock the door open:
 - Fully open the oven door (fig. 13).
 - Fully open the lever **A** on the left and right hinges (Fig 14).
 - Gently close the door (Fig. 15) until the left and right hinges are hooked to part **B** of the door (Fig. 14).
2. Remove the inner pane:
 - Top oven door only: remove the seal **G** by unhooking the no. 3 fixing hooks (fig. 16).
 - Gently pull out the inner pane of glass (Fig. 17).
 - Clean the glass with an appropriate cleaner. Dry thoroughly, and place on a soft surface.

Now you can also clean the inside of the outer glass.

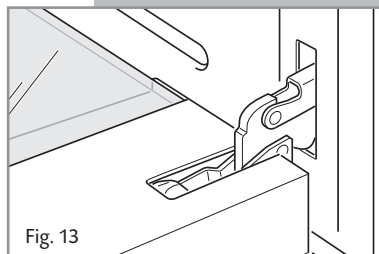
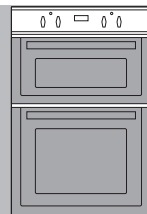

Fig. 13

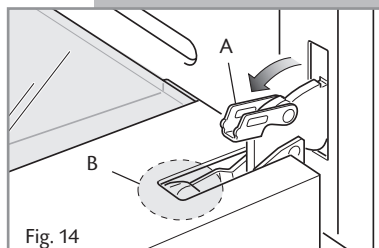

Fig. 14

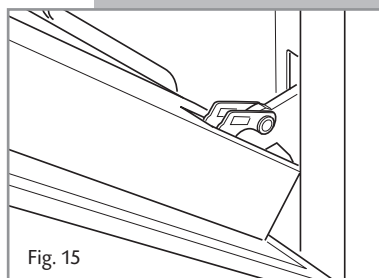

Fig. 15

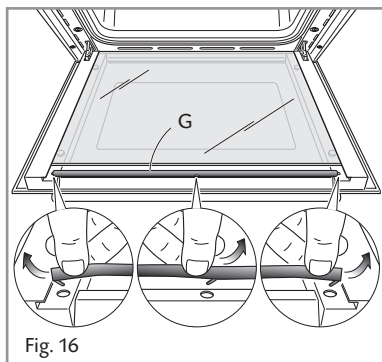

Fig. 16

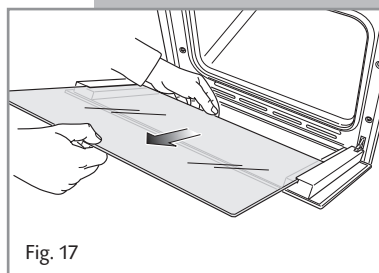

Fig. 17

Replacing the Inner Pane of Glass

1. Make sure the door is locked open (see fig. 15).
2. Replace the inner pane:
 - Check that the four rubber pads are in place (**D** in Fig. 18).
 - Check that you are holding the pane the correct way. You should be able to read the wording on it as it faces you.
 - Insert the pane in the left **E** and right **F** slide guides (fig. 19), and gently slide it to the retainers **H** (fig. 20).
 - Top oven door only: reassemble the seal **G** in the correct way (fig. 21) by hooking the no. 3 fixing hooks in the proper holes (fig. 22).
 - Unlock the oven door by opening it completely and closing the lever **A** on the left and right hinges (Fig. 23).

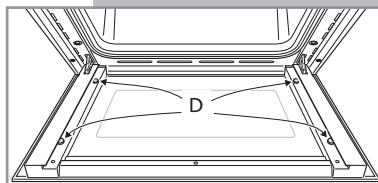

Fig. 18

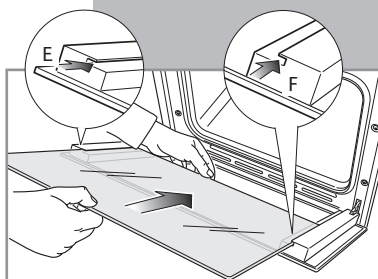

Fig. 19

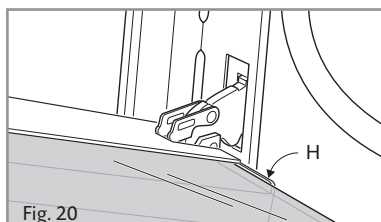
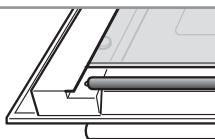

Fig. 20

The top oven door has a sealed gasket in the top part.



It is normal the opened gap between the top edge of the inner glass and the sealed gasket. This allows the cooling air circulation.

The bottom oven door has not a sealed gasket in the top part.

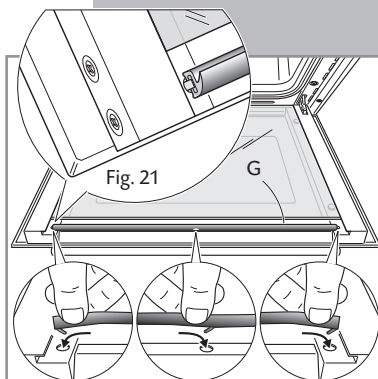
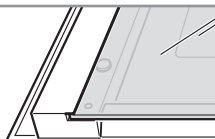

Fig. 22

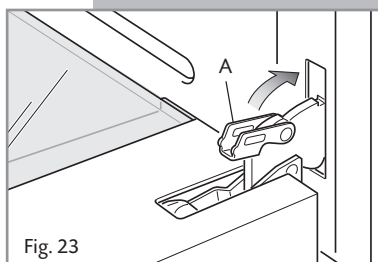

Fig. 23

ADVICE FOR THE INSTALLER

Important

Appliance installation and maintenance must only be carried out by QUALIFIED TECHNICIANS and in compliance with the local safety standards.

- Failure to observe this rule will invalidate the warranty.
- Always disconnect the appliance from the electrical supply before carrying out any maintenance operations or repairs.
- The walls surrounding the oven must be made of heat-resistant material.
- Taking care NOT to lift the oven by the door handle.

WARNING

When correctly installed, your product meets all safety requirements laid down for this type of product category.

However special care should be taken around the rear or the underneath of the appliance as these areas are not designed or intended to be touched and may contain sharp or rough edges, that may cause injury.

Important

- You need the following housing area to fit your oven correctly.
- The double oven is designed to fit into a cabinet of 600 mm width.
- The double oven can be built in the kitchen units, but you must ensure that it is properly ventilated.
- In the diagram the appliance is ventilated by means of the space in the top of the kitchen cabinet.
- Lift the appliance into position onto the shelf, taking care NOT to lift it by the door handles.
- Remember the housing should not be free standing but be secured to the wall and/or adjacent fittings.

WARNING

- We would point out that the adhesive which bonds the plastic laminate to the furniture must withstand temperatures not less than 150° C to avoid delamination.
- The appliance must be housed in heat resistant units.
- **The walls of the units must be capable of resisting temperatures of 75 °C above room temperature.**

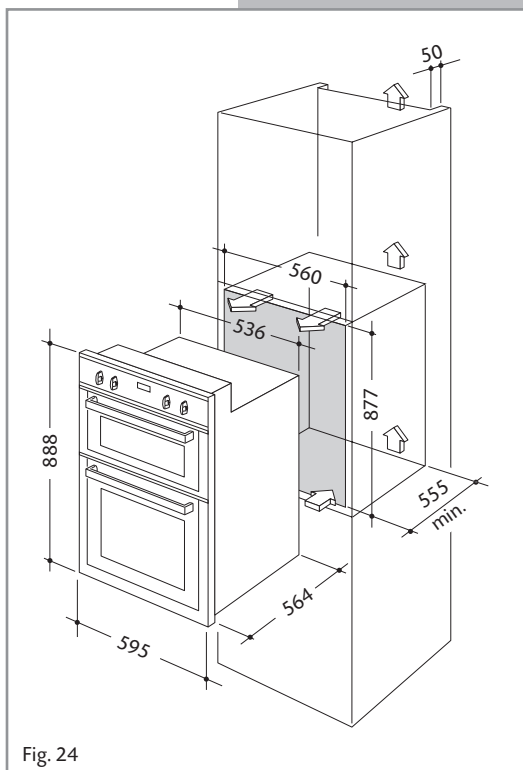

Fixing the Double Oven

Introduce the oven into the furniture opening and fix it with screws (not supplied) as figure 25. It is essential that the oven rests on a surface which will support its weight, as the screw fixing is only complementary.

Note

It is essential that when installing your oven adequate air circulation is allowed for within the installation. Inadequate air circulation may greatly impair the performance of your oven and may effect adjacent cabinets due to an increase in temperature.

Caution

Do not lift this oven by the door handles.

Adjust the hinges of furniture doors adjacent to the oven to allow a 4-5 mm gap between the furniture door and the oven frame.

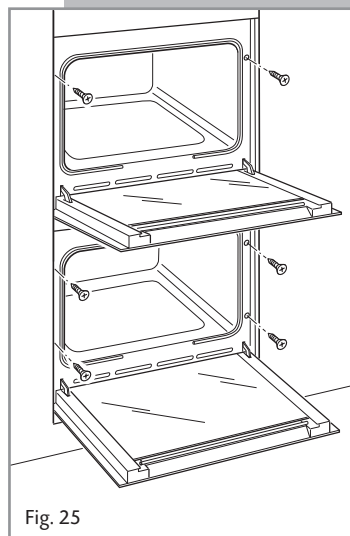
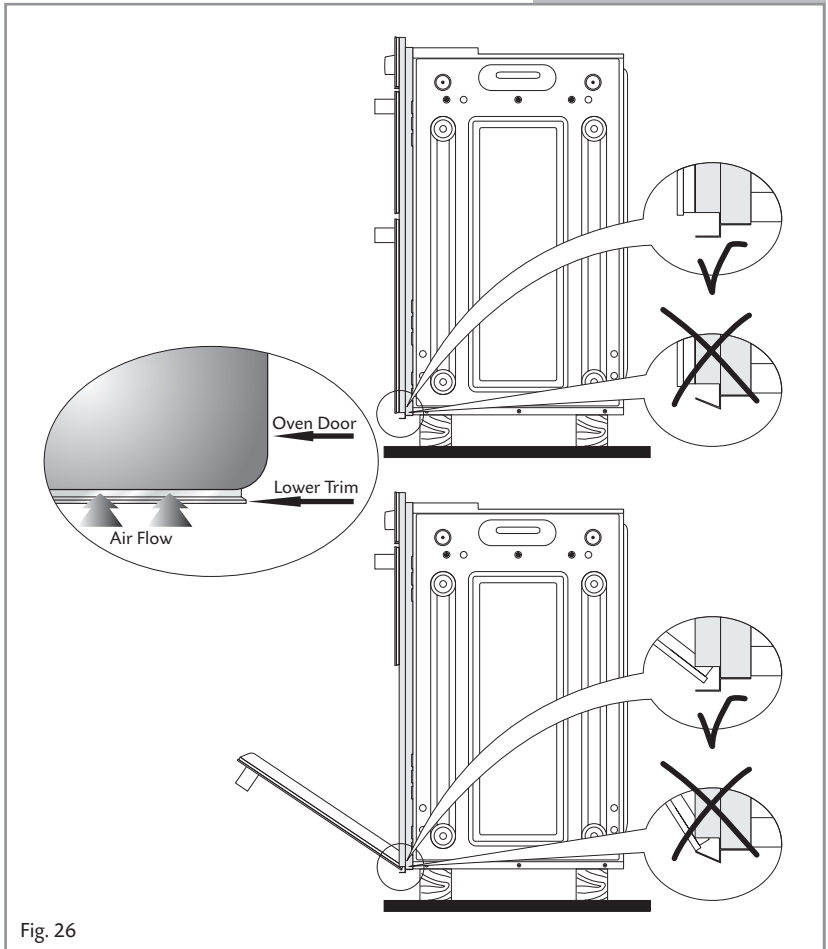

Fig. 25

IMPORTANT:

- To avoid damage to the lower trim please note the following instructions.
- The lower trim is designed to allow for good air circulation and the correct opening of the oven door.
- To ensure the trim is not damaged due to the appliance being placed on the floor, the appliance should be suitably supported as in below illustrations.
- After installation the appliance door should be slowly opened to ensure no damage has occurred.
- **No responsibility for lower trim damage will be accepted if these instructions have not been followed.**



Electrical Installation

For your safety please read the following information:

WARNING! Before effecting any intervention on the electrical parts the appliance must be disconnected from the network.

IMPORTANT: The oven must be installed in accordance with the manufacturer's instructions. Incorrect installation, for which the manufacturer accepts no responsibility, may cause damage to persons, animals and things.

General

- The connection to the electrical network must be carried out by qualified personnel and must be according to existing norms.
- The appliance must be connected to the electrical network verifying above all that the voltage corresponds to the value indicated on the specifications plate and that the cables section of the electrical plant can bear the load which is also indicated on the plate.
- The appliance can be connected directly to the mains placing an omnipolar switch with minimum opening between the contacts of 3 mm between the appliance and the mains.
- The power supply cable must not touch the hot parts and must be positioned so that it does not exceed 75°C at any point.
- Once the appliance has been installed, the switch must always be accessible.
- If the power supply cable is damaged it must be substituted by a suitable cable.

IMPORTANT: this double oven must be connected to a suitable double pole control unit adjacent to the oven.

NO DIVERSITY CAN BE APPLIED TO THIS CONTROL UNIT.

Feeder Cable Section

Type H05RR-F or H05VV-F

230 V~ 3 x 2.5 mm² (**)

(**) – Connection to wall-mounting distribution panel.

The connection of the appliance to the grounding unit is mandatory. The manufacturer declines every responsibility for any inconvenience resulting from the inobservance of this condition.

Connection the Double Oven Mains Cable

Important!

This oven must be connected to the mains power supply only by a suitably qualified person.

Unscrew the screw **A** securing the cover plate **B** behind the oven (fig. 27).

- Remove the cover plate **B**.
- Remove the screws **C** from the cable clamp (fig. 28).
- Insert the mains cable (type H05RR-F or H05VV-F - 3x2,5 mm² section) into the cable protector **P**.
- Connect the phase and earth cables to the mains terminal connection block **D**.

	EARTH
N	NEUTRAL
L	LIVE

- Refit the cable clamp so that it clamps the outer sleeving of the cable, and screw the screws **C**.
- Refit the cover plate **B** and fix it with the screw **A**.

WARNING: This appliance must be earthed

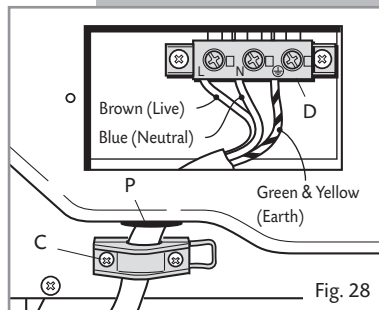
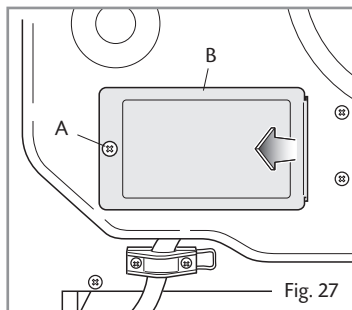

Appliance Servicing

CDA provide a quality and effective after-sales service to cover all your servicing needs.

Please attach your receipt to this page for safekeeping.

Please help us to help you by having the following information available when booking a service-call:

1. Model type, make and model – see the product data plate.
2. Evidence of installation / purchase date
3. Retailer where appliance was purchased
4. Clear and concise details of the fault
5. Full address including postcode and any contact phone numbers

Contact telephone numbers

CDA Customer Care Department

– Telephone: 01949 862012

– Fax: 01949 862003

– Email: service@cda.eu

Guarantee

CDA appliances carry a five-year parts and a one-year labour guarantee.

CDA will repair or replace any defect or part attributable to faulty material or workmanship. Within the first year this will be free of both labour and parts charges. After the first year and within five years, the parts will be supplied free of charge provided that the repair is carried out by an agent authorised by CDA and the labour will be charged at the commercial rate applicable at the time of repair.

The appliance must have been installed by a suitably qualified person and in accordance with the manufacturer's instructions and current legislation. The guarantee does not cover faults caused by the incorrect fitting of appliances.

Limit of Cover

- The guarantee does not cover cosmetic damage e.g. discolouration or oxidation.
- Proof of purchase or installation date must be produced before a service-call will be booked.
- The appliance must be used for domestic purposes only. Appliances used for commercial or professional purposes are not covered by the guarantee. Commercial warranty is available at extra cost.
- The appliance must not be modified or tampered with or repair attempted by any unauthorised person.
- The guarantee does not cover damage caused in transit or by misuse, accident, abuse or neglect.
- The guarantee does not cover routine maintenance.
- Use of parts not supplied or recommended by |C|D|A| will invalidate the warranty.
- Rubber seals, filters, removable glass parts, control knobs and buttons, fuses and light bulbs will need replacing periodically and are not covered by the guarantee.
- Second-hand or reconditioned appliances are not covered by the guarantee.

The conditions under which this guarantee is offered are in addition to the statutory rights of the domestic purchaser and these statutory rights are not affected by this guarantee.

CDA reserve the right to change specification without prior notice.



To contact our Customer Care Department, or for Service,
please contact us on the details below.