

Taking care of your tap

Taps should only be cleaned with a damp cloth or sponge, and dried with a soft cloth.

DO NOT use chemical or cream cleaners, or solutions with bleach content. This can affect the finish of the tap. Please ensure any cloth that has been used with such cleaners is rinsed thoroughly before being used on the tap.

DO NOT use abrasive or wire cleaners.

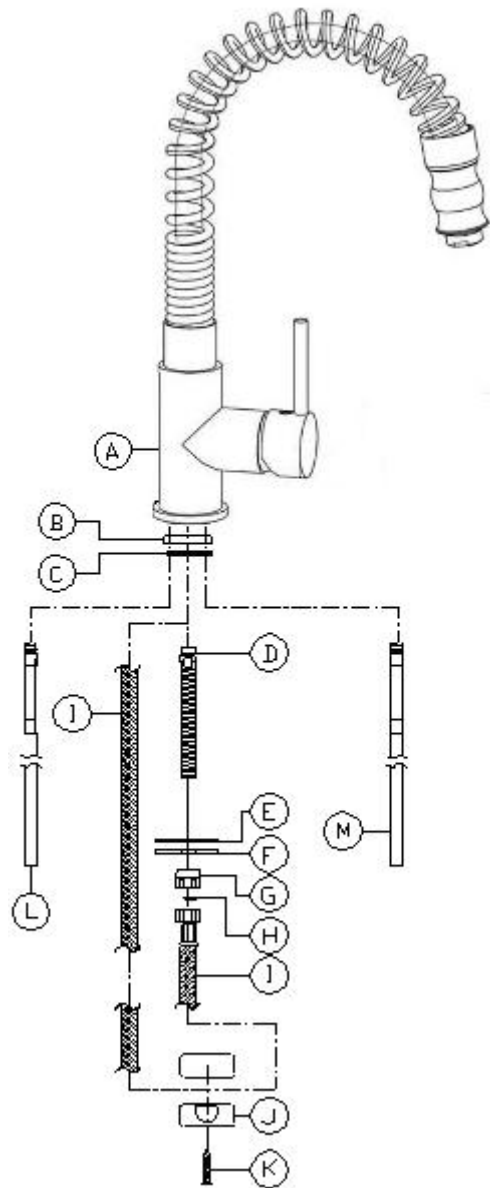

Key:	Description:	Qty
A	Mixertap body	1
B	Base plinth	1
C	Upper seal	1
D	Hollow fixing stud	1
E	Rubber horseshoe	1
F	Metal horseshoe	1
G	Fixing nut	1
H	Fibre washer	1
I	Nylon hose	1
J	Hose weight	1
K	Hose weight screws	2
L	Hot rigid tail pipe	1
M	Cold rigid tail pipe	1

THIS GUARANTEE IS VALID PROVIDING THAT:

- The product has been installed by a suitably qualified person.
- Installation has been carried out in accordance with instructions and current legislation.
- Proof of purchase can be produced.
- The product has been used for domestic purposes only.
- The product has not been tampered with or repair attempted or modified by any unauthorised person.
- **All products have been installed in accordance local water by laws**

THIS GUARANTEE DOES NOT COVER:

- Damage by misuse, neglect or transit.
- Use of parts not used or recommended by CDA.
- Routine maintenance, general wear & tear and installation faults.
- Products used for commercial or professional purposes.

Your tap is guaranteed against defects in materials and/or workmanship for 5 years. At the discretion of CDA, should a fault arise the tap may be repaired or replaced and agreed refitting may be reimbursed on receipt on a faulty tap/part, once they have been inspected and deemed faulty.

The CDA Group Ltd
Harby Road
Langar
Nottinghamshire
NG13 9HY

Telephone: 01949 862012

Customer Care
Fax: 01949 862003
Website: www.cda.eu

Email: service@cda.eu