



# FW422

## Integrated In Column Larder Fridge

Installation, use and maintenance



---

## Contents:

- 3 Important information
- 5 Important safety warnings
- 6 Before first use
- 7 Setting the temperature
- 7 Guidance on use
- 8 Care and cleaning
- 9 Defrosting the fridge
- 10 Changing the light bulb
- 11 Troubleshooting
- 13 Installation
- 14 Electrical information

# Important

The CDA Group Ltd cannot be held responsible for injuries or losses caused by incorrect use or installation of this product. Please note that CDA reserve the right to invalidate the guarantee supplied with this product following incorrect installation or misuse of the appliance.

This appliance is not designed to be used by people (including children) with reduced physical, sensorial or mental capacity, or who lack experience or knowledge about it, unless they have had supervision or instructions on how to use the appliance by someone who is responsible for their safety.

Under no circumstances should any external covers be removed for servicing or maintenance except by suitably qualified personnel.

## **Appliance information:**

Please enter the details on the appliance rating plate below for reference, to assist CDA Customer Care in the event of a fault with your appliance and to register your appliance for guarantee purposes.

Appliance Model	
-----------------	--

Serial Number	
---------------	--

## **CE Declarations of Conformity:**

This appliance meets the requirements of all applicable EU directives with the corresponding harmonised standards which provide for CE marking.

---

This appliance has been manufactured to the strictest standards and complies with all applicable legislation, including Electrical safety (LVD) and Electromagnetic interference compatibility (EMC). Parts intended to come into contact with food conform to 1935/2004/EC.

**IMPORTANT INFORMATION FOR CORRECT DISPOSAL OF THE PRODUCT IN ACCORDANCE WITH EU DIRECTIVE 2012/19/EU.**

At the end of its working life, the product must not be disposed of as urban waste. It must be taken to a special local authority differentiated waste collection centre or to a dealer providing this service.

Disposing of a household appliance separately avoids possible negative consequences for the environment and health deriving from inappropriate disposal and enables the constituent materials to be recovered to obtain significant savings in energy and resources. As a reminder of the need to dispose of household appliances separately, the product is marked with a crossed-out wheeled dustbin. 

## Important

Never store inflammable or explosive items and strong corrosive acids or alkalis in the appliance.

This is a household appliance, which is produced in accordance with the national standard. It is intended for food storage only, not for storage of blood, medicine and biological products.

To prevent risk of fire, keep the appliance away from petrol or any other inflammables.

To prevent risk of electromagnetic interference or other accidents, do not place a microwave oven on top of the refrigerator or use any electric appliance inside the refrigerator.

Do not allow children to play with or near the appliance.

The internal surface of the fridge compartment is very cold when the appliance is running. Do not touch the surface especially with wet hands.

Do not splash water onto the appliance. Keep it away from places of high humidity that may have adverse effect on the electric insulation performance.

Please remove the door, door seal and shelves before disposal of the old appliance and put them away in a safe place to prevent children from being entrapped.

---

## Before first use

**You must allow the fridge to settle for at least twenty four hours prior to switching the power on.**

It is recommended that you clean the interior of the appliance prior to first use, using a solution of bicarbonate of soda and warm water and then thoroughly drying the interior.

The fridge may have an odour to it at first use. This will disappear as the appliance cools.

### **Please note:**

The appliance will work continuously until it comes down to the correct temperature.

If the appliance is switched off, you should allow five minutes before switching it on again to prevent unnecessary damage to the compressor.

This fridge cools your food by making the inside back of the cavity cold. It is normal for frost to build up on this surface; it then dissipates and drains through a small drain at the bottom, where it evaporates harmlessly. The presence of frosting at the back is not a malfunction of the fridge.

# Setting the temperature

**You must allow the fridge to settle for at least twenty four hours prior to switching the power on.**

To adjust the temperature turn the thermostat control knob clockwise (from off) to the required level. The temperature becomes colder the higher the number on the control.

When the thermostat is set to 0 the cooling system is switched off.

We recommend initially setting the temperature control in mid range for the first 24 hours then adjusting the temperature up or down from this point as your personal preference.

## Use

### Fridge

- Never put liquids in the refrigerator uncovered.
- Never put hot foods in the refrigerator. Warm food should be allowed to cool to room temperature before being put into the refrigerator.
- Nothing should rest against the rear wall of the refrigerator, as this will cause frost and possible condensation problems which will be difficult to remove.
- Make sure food is clean and any extra water is wiped away before putting into the fridge.
- Wrap or cover food before putting into the fridge. This will help prevent the loss of moisture, keep food fresh and avoid unpleasant odours.
- Sort foods prior to storing. Any foods to be used soon should be

---

stored at the front of the shelf to prevent deterioration caused by the door being open for prolonged periods.

- Do not overfill the fridge. There should be sufficient space between the foods to allow the cool air to circulate.
- Thawing frozen foods in the fridge compartment will help to keep the temperature low and save energy.
- Only open the door for as long as is necessary. Leaving the door open for long periods will affect the temperature inside the appliance and waste energy.
- Ensure all compartments are fully closed after use.

## Care and cleaning

**Always disconnect the appliance from the power supply before any cleaning or maintenance.**

The fridge sections should be cleaned using a solution of bicarbonate of soda and lukewarm water. Do not use abrasive products or detergents. After washing, rinse and dry thoroughly.

Clean the shelves and balconies separately by hand with soap and water. Do not put them in the dishwasher.

The water drain hole at the back of the fridge compartment and the evaporating tray should be cleaned periodically to prevent the defrosted water from collecting inside the fridge compartment. The drain plug can be used to clean the drain hole.

Once cleaning is complete, then reconnect the power.



- Keep the door gasket (seal) clean. If damaged, the gasket should be replaced.
- If the appliance is not used for prolonged periods of time, unplug and clean the appliance. The door should be left slightly open to prevent the formation of mildew and smell.

## Defrosting the fridge

The fridge is self-defrosting. Any water created will run out of the fridge through the channel at the back of the fridge provided it is not blocked or iced over.

It is important to keep the channel clear at all times. The defrosted water is collected in the evaporating tray at the back of the appliance. Use the supplied drain plug to clean the drain hole (Fig. 1).

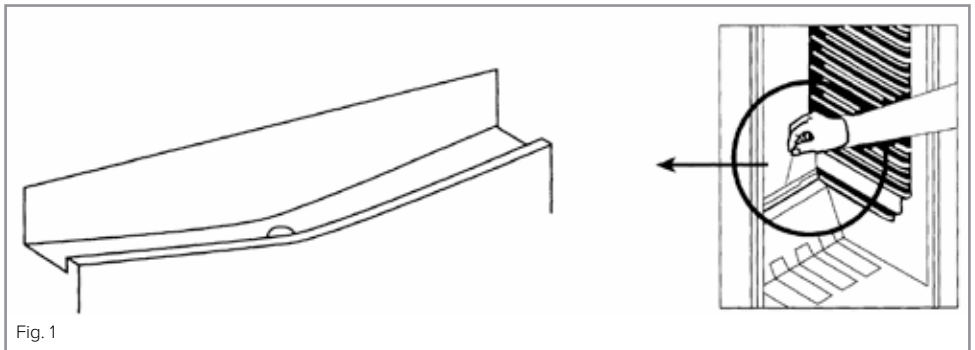

# Changing the light bulb

## **If your fridge has a halogen bulb:**

- **Disconnect the appliance from the power.**
- Carefully remove the light cover by pushing in the lever at the back of the cover, and then pulling the cover down.
- Unscrew the old light bulb to remove it and replace with a new bulb (not more than 15W). Be careful as the bulb may be hot. Always wear adequate protection for your hands. Please note that you can fit a 15W LED bulb if you prefer.
- Replace the light cover and reconnect the power after five minutes' delay as explained on page 3.

## **If your fridge has LED lighting:**

- **Disconnect the appliance from the power.**
- Carefully remove the screw from the light cover. Then, remove the cover by simply pulling it firmly away from the housing. Do not worry if the housing moves slightly - reinserting the screw later will remedy this.
- Unscrew the old light bulb to remove it and replace with a new LED bulb (not more than 15W). Be careful as the bulb may be hot. Always wear adequate protection for your hands.
- Replace the cover by replacing the cover lip nearest the thermostat dial first and then slot the remaining lips in. Reinsert the screw and tighten. Reconnect the power after five minutes' delay as explained on page 3.

# Troubleshooting

If you have any problems with your appliance, you should check the troubleshooting prior to calling CDA Customer Care to prevent unnecessary service calls and potential cost.

## **If the appliance is not working, check:**

- There is power to the appliance:
- The house fuses are intact and the fuse in the plug has not blown.
- The thermostat is not set to 0 (off position).
- The plug socket is functioning correctly. To check this, plug another electrical appliance in to see if the socket is working.
- The temperature of the room is adequate (10°C or above).

## **If the appliance is working, but not very well, check:**

- The appliance is not overloaded.
- The thermostat is set to an appropriate temperature.
- The door is closing properly.
- The cooling system at the rear of the appliance is clean and free of dust, and not touching the rear wall.
- There is enough ventilation at the side and rear walls.
- The temperature of the room is adequate (10°C or above).

## **If the appliance is noisy, check:**

- The appliance is level and stable.
- The side and rear walls are clear, and there is nothing resting on the appliance.
- The cooling gas in the refrigerator will make a slight bubbling noise, even when the compressor is not running.

---

**If there is water in the lower part of the refrigerator compartment, check the following:**

- The drain hole in the channel at the back of the compartment is clear.
- There are no items touching the rear wall of the appliance. If there are, adjust their position so that they no longer touch it.
- Check that there is some resistance when opening the door of the appliance. If it opens at the slightest touch it may mean that the door seal needs to be replaced.
- Check the door seal for any kinks, debris or damage. If you notice any, and are unable to resolve the issue yourself, contact CDA Customer Care so that the seal can be replaced.

**If ice has formed on the back wall of the fridge:**

- It is normal for some ice droplets to form on the back wall of the fridge. This does not constitute a fault with the appliance.
- Ensure that no items inside the fridge are in contact with the back wall.
- Check that there is some resistance when opening the door of the appliance. If it opens at the slightest touch it may mean that the door seal needs to be replaced.
- Check the door seal for any kinks, debris or damage. If you notice any, and are unable to resolve the issue yourself, contact CDA Customer Care so that the seal can be replaced.

# Installation

**This appliance must never be installed close to heat sources such as radiators, heating elements, cookers or in damp places. Nor should it be installed in rooms or areas (such as garages) whose ambient temperature will fall or rise outside of the climate class limitations (approx. +16°C to +43°C).**

This appliance is designed to be installed into a standard larder unit of width 560-570mm and a minimum depth of 550mm (560mm is recommended). There is a template supplied with the appliance that offers an illustrated, step by step, installation guide.

Note that the figure beneath the kit contents on the installation template shows ventilation requirements. In the diagram a plinth vent is fitted to allow free air into the cabinet. This is not necessary where there is already a free air supply into the run of units provided by a vent in another unit (or side of the run). The more air that can enter and leave the units though, the more efficient the appliance shall be.

# Electrical information

**Warning! This appliance must be earthed.**

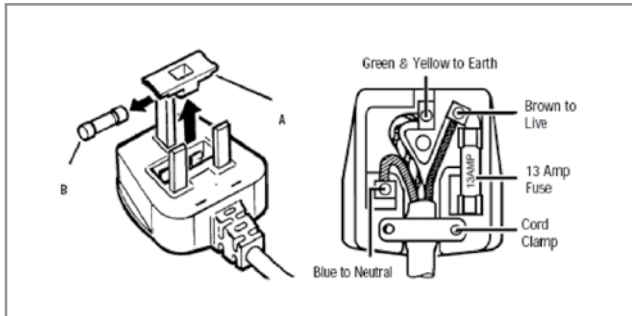

The mains lead of this appliance has been fitted with a BS 1363A 13 amp fused plug. To change a fuse in this type of plug, follow the steps below:

1. Remove the fuse cover and fuse.
2. Fit replacement 13A fuse, ASTA approved to BS 1362 type, into the fuse cover.
3. Replace fuse cover.

**Important: Do not use the appliance without the fuse cover in position.**

## How to connect an alternative plug

If the fitted plug is not suitable for your socket outlet, then it should be cut off and disposed of safely to prevent the risk of electric shock. A suitable alternative plug of at least 13 Amp rating to BS 1363 should be used.

As the colours of the wires in the mains lead of this appliance may not correspond with the coloured markings identifying the terminals in your plug, proceed as follows:

- The wire which is coloured GREEN and YELLOW must be connected to the terminal which is marked with letter (E) or by the Earth symbol  or coloured GREEN and YELLOW.
- The wire which is coloured BLUE must be connected to the terminal which is marked with the letter (N), or coloured BLACK.
- The wire which is coloured BROWN must be connected to the terminal which is marked with the letter (L) or coloured RED.

If in doubt regarding the electrical connection of this appliance, consult a qualified electrician. Do not shorten the supply cable, the appliance may require removing for servicing.

**N.B. Ensure that the plug socket is situated in an easily accessible place.**

**If the power supply cord is damaged, it must be replaced by a CDA authorised agent.**



**For service or queries relating to your product please contact:**

The Customer Care Department on **01949 862 012** or email [customer.care@cda.eu](mailto:customer.care@cda.eu)

**For more information please contact:**

The Sales Department on **01949 862 010** or email [sales@cda.eu](mailto:sales@cda.eu)

**Customer Care Department.** The CDA Group Ltd, Harby Road, Langar, Nottinghamshire, NG13 9HY  
T: 01949 862 012 F: 01949 862 003 E: [customer.care@cda.eu](mailto:customer.care@cda.eu)