



FW925

Integrated Fridge Freezer

Installation, use and maintenance



Contents:

- 3 Important information
- 5 Important notes
- 5 Before first use
- 6 Important notes on use of the fridge
- 7 Important notes on use of the freezer
- 9 Storage
- 10 Control panel
- 11 Care and cleaning
- 12 Defrosting the fridge
- 12 Defrosting the freezer
- 13 Troubleshooting
- 15 Installation preparation
- 15 Ventilation requirements
- 17 Installation into the cabinet
- 18 Mounting the fascia doors
- 20 Reversing the appliance doors
- 21 Electrical information
- 23 Energy efficiency information

Important

The manufacturer cannot be held responsible for injuries or losses caused by incorrect use or installation of this product. Please note that we reserve the right to invalidate the guarantee supplied with this product following incorrect installation or misuse of the appliance.

This appliance is not designed to be used by people (including children) with reduced physical, sensorial or mental capacity, or who lack experience or knowledge about it, unless they have had supervision or instructions on how to use the appliance by someone who is responsible for their safety.

Under no circumstances should any external covers be removed for servicing or maintenance except by suitably qualified personnel.

Appliance information:

Please enter the details on the appliance rating plate below for reference, to assist CDA Customer Care in the event of a fault with your appliance and to register your appliance for guarantee purposes.

| | |
|-----------------|--|
| Appliance Model | |
|-----------------|--|

| | |
|---------------|--|
| Serial Number | |
|---------------|--|

EU Declarations of Conformity:

This appliance has been designed, constructed and marketed in compliance with safety requirements of EU Directive 2014/35/EU (Low voltage) and requirements of EU Directive 2014/30/EU (EMC).

This appliance has been manufactured to the strictest standards and complies with all applicable legislation, including Electrical safety (LVD) and Electromagnetic interference compatibility (EMC). Parts intended to come into contact with food conform to 1935/2004/EC.

IMPORTANT INFORMATION FOR CORRECT DISPOSAL OF THE PRODUCT IN ACCORDANCE WITH EC DIRECTIVE 2012/19/EU.

At the end of its working life, the product must not be disposed of as urban waste. The refrigeration system contains insulating gases and refrigerants, which require specialised waste disposal. The valuable materials contained in this appliance can be recycle. It must be taken to a special local authority differentiated waste collection centre or to a dealer providing this service.

Before disposing of an old appliance, remove the door seals etc. to reduce the risk of child entrapment.

Disposing of a household appliance separately avoids possible negative consequences for the environment and health deriving from inappropriate disposal and enables the constituent materials to be recovered to obtain significant savings in energy and resources. As a reminder of the need to dispose of household appliances separately, the product is marked with a crossed-out wheeled dustbin. 

Important

- Never store inflammable or explosive items and strong corrosive acids or alkalis in the appliance.
- This is a household appliance, which is produced in accordance with the national standard. It is intended for food storage only, not for storage of blood, medicine and biological products.
- To prevent risk of fire, keep the appliance away from petrol or any other inflammables.
- To prevent risk of electromagnetic interference or other accidents, do not place a microwave oven on top of the refrigerator or use any electric appliance inside the refrigerator.
- Do not allow children to play with or near the appliance.
- The internal surface of freezer compartment is very cold when the appliance is running. Do not touch the surface especially when hands are wet.
- Do not splash water onto the appliance. Keep it away from places of high humidity that may have adverse effect on the electric insulation performance.
- This appliance is designed to be used in ambient temperatures between 10 and 32°C. Use outside of this range may cause the appliance to fail.

Before first use

You must allow the fridge to settle for at least twenty four hours prior to switching the power on.

It is recommended that you clean the interior of the appliance prior to first use, using a solution of bicarbonate of soda and warm water and then thoroughly drying the interior.

The fridge may have an odour to it at first use. This will disappear as the appliance cools.

Please note:

The appliance will start on temperature setting 3 and work continuously until it comes down to the correct temperature. If the appliance is switched off, you should allow five minutes before switching it on again to prevent unnecessary damage to the compressor.

Never store inflammable or explosive items and strong corrosive acids or alkalis in the appliance.

This fridge cools your food by making the inside back of the cavity cold. It is normal for frost to build up on this surface; it then dissipates and drains through a small drain at the bottom, where it evaporates harmlessly. The presence of frosting at the back is not a malfunction of the fridge.

Fridge use

- Never put liquids in the refrigerator uncovered.
- Never put hot foods in the refrigerator. Warm food should be allowed to cool to room temperature before being put into the refrigerator.
- Nothing should rest against the rear wall of the refrigerator, as this will cause frost and possible condensation problems which will be difficult to remove.
- Make sure food is clean and any extra water is wiped away before putting into the fridge.
- Wrap or cover food before putting into the fridge. This will help

prevent the loss of moisture, keep food fresh and avoid unpleasant odours.

- Sort foods prior to storing. Any foods to be used soon should be stored at the front of the shelf to prevent deterioration caused by the door being open for prolonged periods.
- Do not overfill the fridge. There should be sufficient space between the foods to allow the cool air to circulate.
- Thawing frozen foods in the fridge compartment will help to keep the temperature low and save energy.
- Never store raw meats on shelves above cooked meats or other produce. This will help to prevent juices from raw meat contaminating other foodstuffs.

Freezer use

- The freezer compartments are designed to store only frozen food.
- Never put hot or warm foods in the freezer, allow them to cool fully before putting them into the freezer.
- Follow the instructions on the food packaging for storage of frozen food. If no information is provided, foods should not be stored for more than three months after the purchase date.
- Store food in small packages (ideally less than 1kg). This reduces the freezing time and improves the quality of the food after thawing.
- Wrap food before putting into the freezer. To stop the wrapping sticking together, ensure it is dry.
- Label the food before freezing with information including type of food and dates of storage and expiry.

-
- Once food is thawed, it must not be refrozen. Only defrost as much food as is required to prevent wastage.
 - Bottled or canned drinks should not be stored in the freezer compartments as they could explode.
 - The maximum amount of fresh food that can be frozen within a 24 hour period is 4.5 kg.
 - Do not attempt to freeze more than the maximum amount.

Storage

The fridge section is for short term food storage. Although low temperatures can be maintained, extended periods of food storage is not recommended.

As the cold air circulates within the fridge, the temperature can vary between the different sections. As such, foods should be stored in different sections according to type. Section 7 is the coldest part of the fridge.

1. Butter, cheeses etc.
2. Food in jars and bottles
3. Drinks, e.g. milk
4. Cooked food
5. Yogurts, preserves etc.
6. 75cl bottles or ready meals etc.
7. Fresh meat and fish
8. Fruit and vegetables

The fridge shelves can be moved according to the storage requirements within the fridge section. To move the shelf, lift up the rear section and then pull it outwards. To replace, slide the shelf back into the slot, and then lower the rear section.

The wine racks can be deployed or withdrawn as desired.

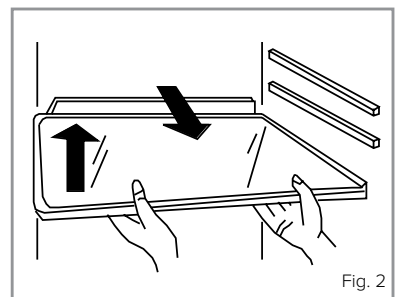
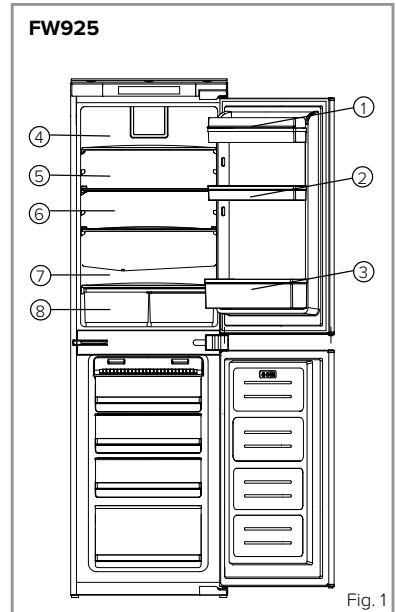

Control Panel

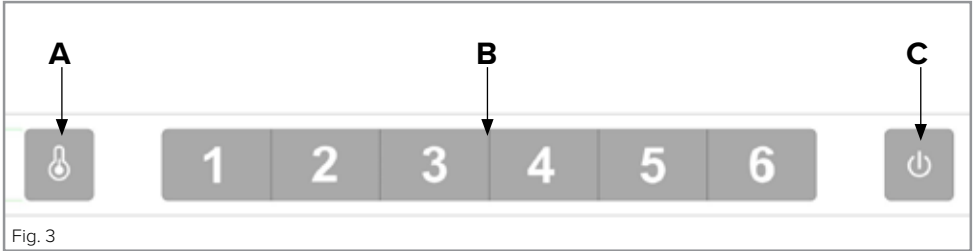

A. Refrigerator temperature adjustment sensor

This button is used to adjust the temperature within the fridge. Press this sensor once to activate adjustment, and then as many times as necessary until the desired level is selected. The settings range from 1 to 6 with 1 being the warmest and 6 being the coldest.

Please note: Where possible, avoid having the temperature setting on 6 all of the time. This will help to alleviate strain on the compressor and refrigeration system.

B. Refrigerator temperature setting display

This display will illuminate the current temperature setting. Adjusting the temperature will cycle through this display.

Please note: You do not use numbers 1 to 6 to change the temperature. Instead, use the refrigerator temperature adjustment sensor (**A**).

C. Power button

Use this sensor to switch the appliance on and off (standby mode). The sensor will be illuminated when the appliance is off.

Care and cleaning

Always disconnect the appliance from the power supply before any cleaning or maintenance.

The fridge and freezer sections should be cleaned using a solution of bicarbonate of soda and lukewarm water. Do not use abrasive products or detergents. After washing, rinse and dry thoroughly.

Clean the shelves and balconies separately by hand with a mild solution of washing up liquid and water. Do not put them in the dishwasher.

The water drain hole at the back of the fridge compartment should be cleaned periodically to prevent the defrosted water from collecting inside the fridge compartment. The drain plug can be used to clean the drain hole.

If the appliance is not to be used for prolonged periods of time, unplug and clean the appliance. The doors should be left slightly ajar to prevent the formation of mildew and unpleasant odours.

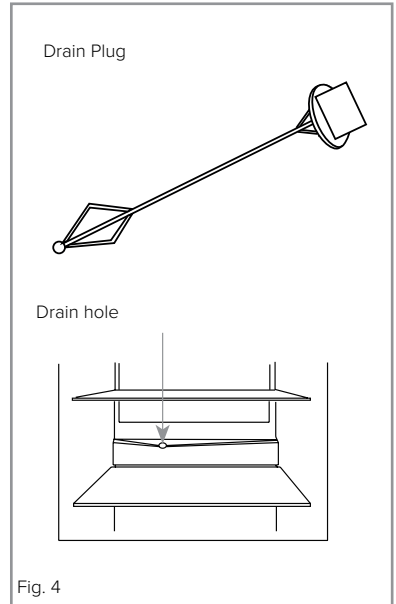

Fig. 4

Defrosting the fridge

The fridge is self-defrosting. Any water created will run out of the fridge through the channel at the back of the fridge, unless the drain hole is blocked (page 11). It is important to keep the channel clear at all times using the cleaning tool supplied. The defrosted water is collected in the evaporating tray at the back of the appliance and dissipated by evaporation.

Defrosting the freezer

The freezer has a no frost system which is designed to prevent the heavy build up of ice. Under normal use, there should be no need to regularly defrost the freezer system.

To help in times of service or cleaning, the appliance has a forced defrost mode which can be activated by touching and holding sensors A and C in Fig. 3 for approximately 3 seconds. The refrigerator temperature adjustment sensor (A) will flash to confirm that the forced defrost function is active. This function should automatically deactivate once the freezer temperature has reached between 10 and 12°C.

Please note: If you are regularly finding a heavy build up of ice, or pools of water, in the freezer section then it is likely that the door is not sealing properly. This could be due to a defective door seal or an incorrectly fitted, or overly heavy, decor door. For more information see the troubleshooting section on ice on page 14.

Troubleshooting

If you have any problems with your appliance, you should check the troubleshooting prior to calling CDA Customer Care.

If the appliance is not working, check:

- That there is power to the appliance.
- The house fuses are intact and the fuse in the plug has not blown.
- The fridge has not been turned off (page 10).
- The plug socket is functioning fine. To check this, plug another electrical appliance in to see if the socket is faulty.

If the appliance is working, but not very well, check:

- The appliance is not overloaded.
- The thermostat is set to an appropriate temperature.
- The doors are closing properly.
- The cooling system at the rear of the appliance is clean and free of dust, and not touching the rear wall.
- There is enough ventilation at the side and rear walls.

If the appliance is noisy, check:

- The appliance is level and stable.
- The side and rear walls are clear, and there is nothing resting on the appliance.
- Note: The cooling gas in the refrigerator may make a slight bubbling or gurgling noise, even when the compressor is not running.

If the appliance is beeping, check:

- That the doors are closed. An alarm will sound after 60 seconds of a door being open.

If there's water in the base of the refrigerator compartment, check:

- The drain hole at the back of the compartment is clear (page 11).

If ice has formed on the back wall of the fridge:

- It is normal for some ice droplets to form on the back wall of the fridge. This does not constitute a fault with the appliance.
- Ensure that no items inside the fridge are in contact with the back wall.
- Check that there is some resistance when opening the door of the appliance. If it opens at the slightest touch it may mean that the door seal needs to be replaced.
- Check the door seal for any kinks, debris or damage. If you notice any, and are unable to resolve the issue yourself, contact CDA Customer Care so that the seal can be replaced.
- This can be due to the decor door(s) not being properly fitted. If you are at all unsure, ask your fitter to check the decor doors.

If excessive ice has formed in the freezer:

- Check that there is some resistance when opening the door of the appliance. If it opens at the slightest touch it may mean that the door seal needs to be replaced.
- Check the door seal for any kinks, debris or damage. If you notice any, and are unable to resolve the issue yourself, contact CDA Customer Care so that the seal can be replaced.
- This can be due to the decor door(s) not being properly fitted. If you are at all unsure, ask your fitter to check the decor doors.

If one or more of the LED units within the appliance is not working:

- Contact CDA Customer Care to arrange a service visit.

Installation preparation

This appliance must never be installed close to heat sources, e.g. heating elements or cookers, nor in damp places.

Seek the help of another individual, or two, when installing this appliance. This appliance may have sharp edges. Wear adequate PPE for the task and environment.

- To ensure the appliance is level, you should use the height adjustable feet at the front of the appliance.
- The cooling system at the rear of the appliance must not touch the rear wall. The greater the gap, the better.
- The appliance must be installed with adequate ventilation. Ensure that there is clearance above the appliance to allow air to escape and that there is space between the rear of the appliance and the wall.

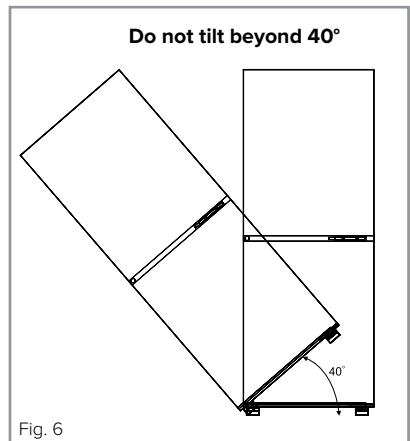
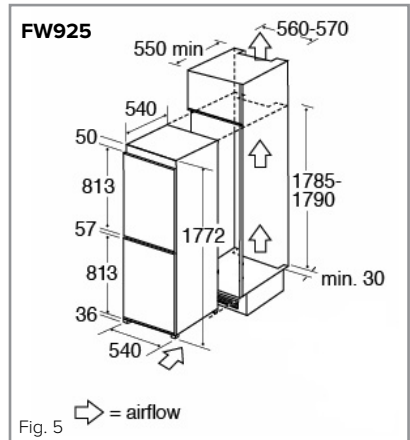

Ventilation

The main consideration when installing any refrigeration unit into a fitted kitchen is ventilation. The heat removed from the cooling compartment needs to be dissipated into the atmosphere. Incorrect ventilation can lead to premature compressor failure, excessive power

consumption, total system failure and may invalidate the warranty provided with the appliance. For products intended to be installed into a tall housing unit, the following requirements need to be met:

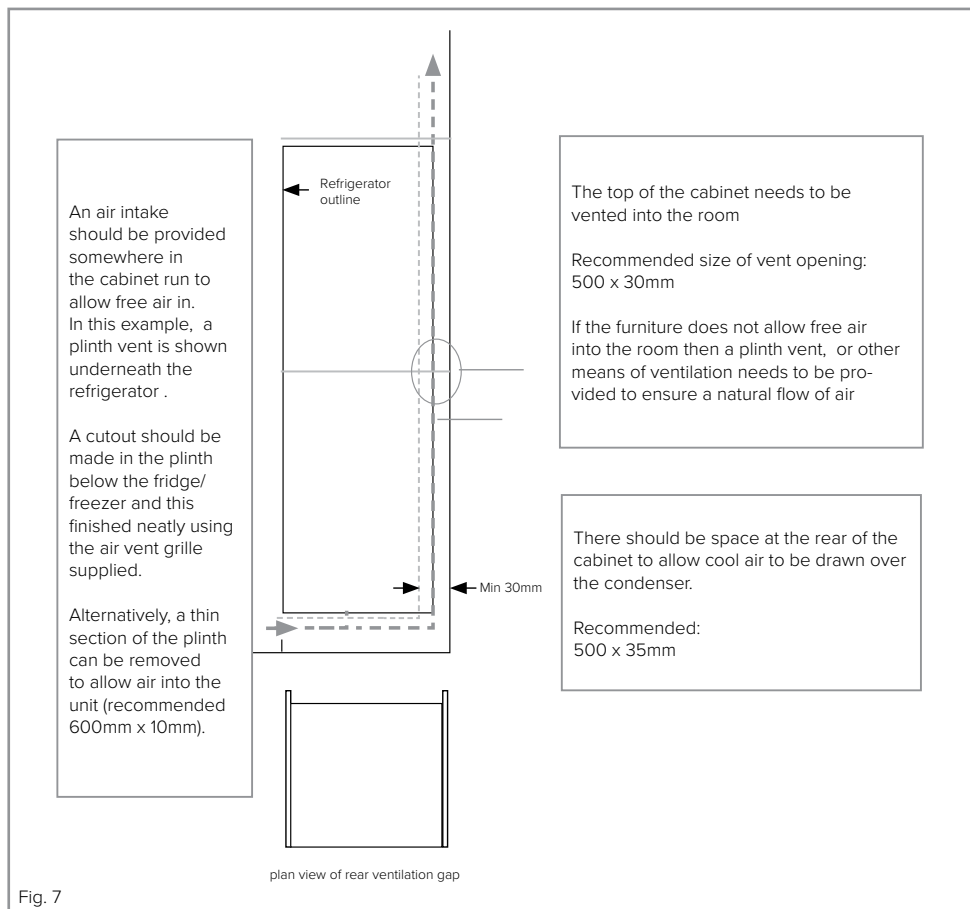

The open channel at the rear is clearly shown. For the correct operation of the appliance it is important that the top of the housing unit is not blocked off. A channel depth of 40-50mm is normal with most units.

A ventilation hole is required in the plinth of the unit; this allows air to

be drawn over the compressor & heat exchange. A decorative grille is supplied with the appliance to finish this vent neatly. Alternatively the required air flow can be achieved by removal of a thin section of plinth (recommended 600mm x 10mm minimum).

As a rule, the more air that can get in and out, the better and more efficient the operation of the product.

Installation into the cabinet

With the help of another individual, or two, manoeuvre the appliance into the cabinet. There are two metal plates at the base of the appliance. Fit the supplied white spacers (Fig. 8) to these plates, as per Fig. 9.

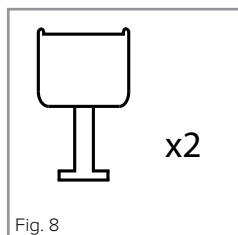

Ensure that the lips of the spacers are level with the lip of the cabinet base.

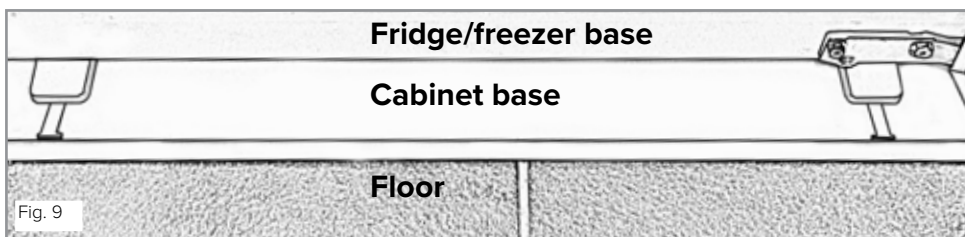

With the base of the appliance aligned correctly with the edge of the cabinet base, the metal trim at the top of the appliance should sit flush against the cabinet edge (if it does not, ensure the base is aligned as per Fig. 9 and that the metal trim in Fig. 10 is not damaged).

Secure the top of the appliance to the top of the cabinet through the metal trim screw holes marked 'T' in fig 10.

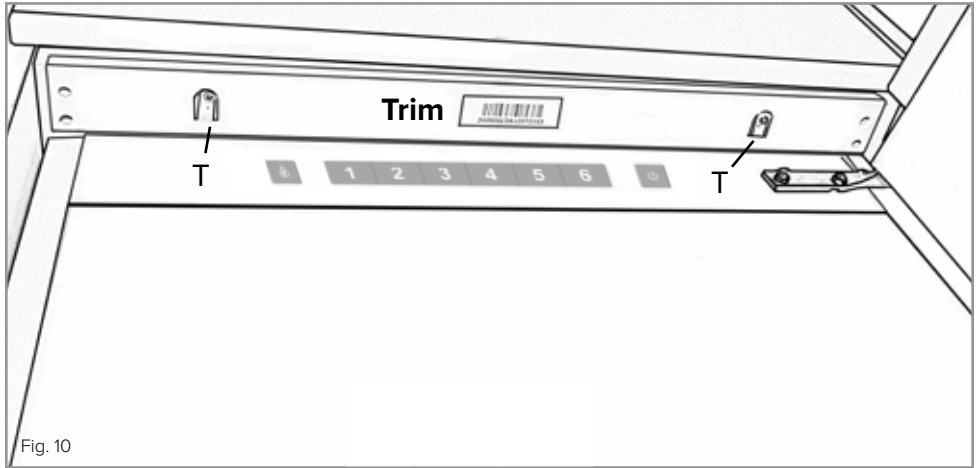

Remove the white spacers from the base plates and secure the plates to the cabinet base using four of the supplied screws. Replace the spacers.

Mounting the fascia doors

- Ensure that there is a gap of 3 to 4mm between the non-hinged side and the cabinet wall.
- Locate the slider in the bracket and fix the slider to the fascia door 20 to 22mm from the edge of the fascia as shown in figure 11, ensuring that the slider is positioned centrally and horizontally within the bracket. Tighten securely by hand.
- Fill the gap on the non-hinged side with the gasket/seal strip provided, as shown in Fig. 12.
- The finished look for the door sliders should be similar to those shown in Fig. 14, which shows 2 sliders in place.
- **Ensure the appliance doors open, close and seal properly.**

Once complete, and if you are happy with the fit of the appliance in the cabinet, bend and snap the parts of the white spacers marked 'S' as shown by the dotted outline in fig. 13. Leave the rest of the spacer cover in place over the metal plates.

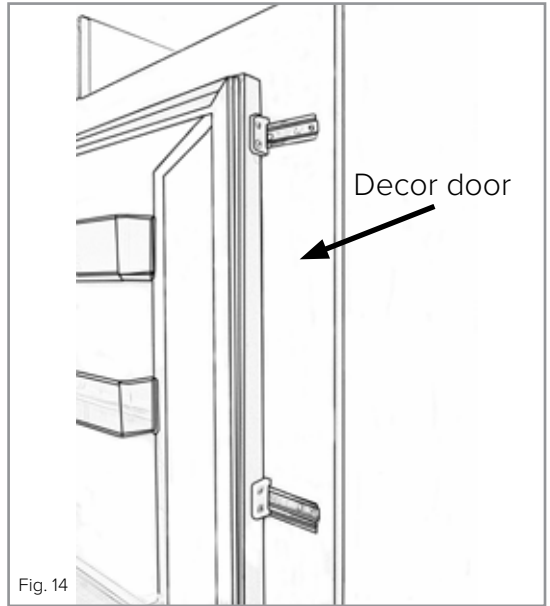
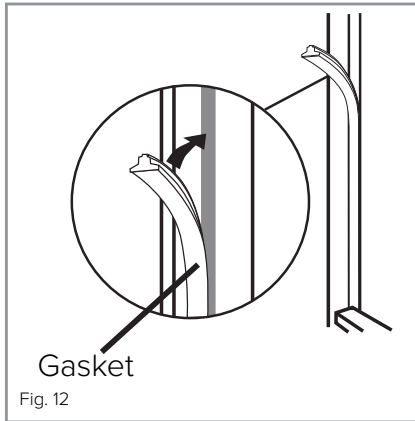
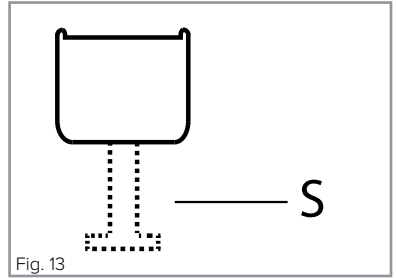
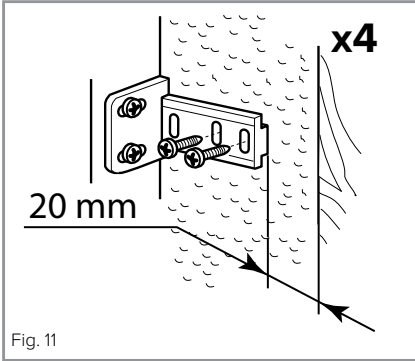

Important: After completing the installation, check that the appliance is secured within the unit and that the door(s) close and open properly. If there is no resistance from the door seals when opening the doors, then it is probable that the appliance and/or decor doors are not fitted properly.

Reversing the appliance doors

We recommend you seek the help of another individual to support the doors whilst performing this operation.

1. Carefully prise off the cover cap for the top hinge and unscrew the screws fixing the top hinge to the appliance, you should support the upper door whilst doing this.
2. Carefully remove the upper door and place it somewhere safe. Note that there are spacers between the door and the hinge; note how many and their position.
3. Remove the central hinge by removing the screws fixing it to the appliance; support the lower door whilst doing this.
4. Remove the lower door and place it somewhere safe, again noting the position of any spacer pieces.
5. Swap the previous top hinge to the opposite side at the bottom.
6. Refit the lower door using any spacers and position the central hinge on the door. After removing the cover caps, fix the hinge securely to the appliance.
7. Swap the previous bottom hinge to the opposite side at the top. Refit the upper door and the “new” top hinge and fix securely to the appliance.
8. Fit the central cover caps and top hinge cover pieces in place to complete the process.
9. Unscrew all four slider brackets from the doors and swap them over to the side furthest from the new hinge positions, before the decor door is fitted.

Ensuring the door seals correctly:

It is normal for the seal to be compressed after the door has been reversed. With the door closed, use a hair dryer to expand the seal and fill the gap between the door and the body of the appliance. Take care not to use the hair dryer too close to the appliance, which could damage the seal. A distance of approximately 10cm should be adequate.

When completed, allow the seal and door to cool before touching them. Once done, the seal should remain in position.

Electrical information

Warning! This appliance must be earthed.

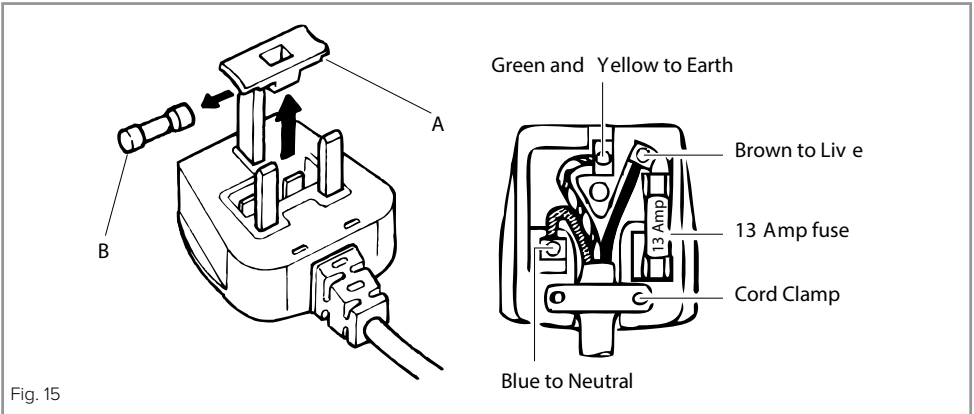

The mains lead of this appliance has been fitted with a BS 1363A 13Amp fused plug. To change a fuse in this type of plug, follow the steps below:

1. Remove the fuse cover and fuse.
2. Fit replacement 13A fuse, ASTA approved to BS 1362 type, into the fuse cover.
3. Replace fuse cover.

Important: Do not use the appliance without the fuse cover in position.

How to connect an alternative plug

If the fitted plug is not suitable for your socket outlet, then it should be cut off and disposed of safely to avoid possible shock hazard. A suitable alternative plug of at least 13 Amp rating to BS 1363 should be used.



As the colours of the wires in the mains lead of this appliance may not correspond with the coloured markings identifying the terminals in your plug, proceed as follows:-

- The wire which is coloured GREEN and YELLOW must be connected to the terminal which is marked with letter (E) or by the Earth symbol \perp or coloured GREEN and YELLOW.
- The wire which is coloured BLUE must be connected to the terminal which is marked with the letter (N) or coloured BLACK.
- The wire which is coloured BROWN must be connected to the terminal which is marked with the letter (L) or coloured RED.

If in doubt regarding the electrical connection of this appliance, consult a qualified electrician. Do not shorten the supply cable, the appliance may require removing for servicing.

N.B. Ensure that the plug socket is situated in an easily accessible place after installation.

Energy Efficiency Information

| Attribute | Symbol | Value | Value | Units |
|--|-----------------|---|---|----------|
| Model identification | | FW925 | FW927 | |
| Category of the household refrigerating appliance | | 7 | 7 | |
| Voltage / Frequency | | 220 - 240V ~ / 50Hz | | |
| Dimensions (W x D x H cm) | | 540 x 540 x 1772 | | |
| Mass of the appliance | M | 62 | 63 | kg |
| Energy efficiency class | | A+ | A+ | |
| Annual energy consumption | A _{Ec} | 280 | 270 | kWh/year |
| The energy consumption is based on standard test results for 24 hours. Actual energy consumption will depend on how the appliance is used and where it is located. | | | | |
| Storage volume (fridge) | | 77 | 56 | L |
| Storage volume (freezer) | | 158 | 190 | L |
| Star rating | |  |  | °C |
| Defrosting type | | Automatic | | |
| Climate class | | N-ST | N-ST | |
| Airborne accoustic noise emissions | pW | 41 | 41 | dB(A) |



For service or queries relating to your product please contact:

The Customer Care Department on **01949 862 012** or email customer.care@cda.eu

For more information please contact:

The Sales Department on **01949 862 010** or email sales@cda.eu

Customer Care Department. The CDA Group Ltd, Harby Road, Langar, Nottinghamshire, NG13 9HY
T: 01949 862 012 **F:** 01949 862 003 **E:** customer.care@cda.eu