



FF820 Freestanding Full Height Larder Fridge

Manual for Installation, Use and Maintenance

Important

The CDA Group Ltd cannot be held responsible for injuries or losses caused by incorrect use or installation of this product. Please note that CDA reserve the right to invalidate the guarantee supplied with this product following incorrect installation or misuse of the appliance.

This appliance is not designed to be used by people (including children) with reduced physical, sensorial or mental capacity, or who lack experience or knowledge about it, unless they have had supervision or instructions on how to use the appliance by someone who is responsible for their safety.

Under no circumstances should any external covers be removed for servicing or maintenance except by suitably qualified personnel.

Appliance information:

Please enter the details on the appliance rating plate below for reference, to assist CDA Customer Care in the event of a fault with your appliance and to register your appliance for guarantee purposes.

Appliance Model	
-----------------	--

Serial Number	
---------------	--

CE Declarations of Conformity:

This appliance has been designed, constructed and marketed in compliance with safety requirements of EEC Directive 2006/95/EEC (Low voltage) and requirements of EMC Directive 2004/108/EEC.

This appliance has been manufactured to the strictest standards and complies with all applicable legislation, including Electrical safety (LVD) and Electromagnetic interference compatibility (EMC). Parts intended to come into contact with food conform to EEC/89/109.4

IMPORTANT INFORMATION FOR CORRECT DISPOSAL OF THE PRODUCT IN ACCORDANCE WITH EC DIRECTIVE 2002/96/EC.

At the end of its working life, the product must not be disposed of as urban waste. It must be taken to a special local authority differentiated waste collection centre or to a dealer providing this service.

Disposing of a household appliance separately avoids possible negative consequences for the environment and health deriving from inappropriate disposal and enables the constituent materials to be recovered to obtain significant savings in energy and resources. As a reminder of the need to dispose of household appliances separately, the product is marked with a crossed-out wheeled dustbin. 

Before First Use

You must allow the fridge to settle for at least twenty four hours prior to switching the power on.

It is recommended that you clean the interior of the appliance prior to first use, using a solution of bicarbonate of soda and warm water and then thoroughly drying the interior.

The fridge may have an odour to it at first use. This will disappear as the appliance cools.

Please note:

- The appliance will work continuously until it comes down to the correct temperature.
- If the appliance is switched off, you should allow five minutes before switching it on again to prevent unnecessary damage to the compressor.
- This fridge cools your food by making the inside back of the cavity cold. It is normal for frost to build up on this surface; it then dissipates and drains through a small drain at the bottom, where it evaporates harmlessly. The presence of frosting at the back is not a malfunction of the fridge.

Use

- Do not use electrical devices inside the refrigerator.
- Do not damage the refrigerant circuit.
- Do not use flammable solvents near the appliance.
- Do not place heavy items on top of the refrigerator.

- Do not splash water onto the top or back of this appliance.
- Never put liquids in the refrigerator uncovered.
- Never put hot foods in the refrigerator. Warm food should be allowed to cool to room temperature before being put into the refrigerator.
- Nothing should rest against the internal rear wall of the refrigerator, as this will cause frost and possible condensation problems which will be difficult to remove.
- Never store inflammable or explosive items and strong corrosive acids or alkalis in the appliance.
- This is a household appliance, which is produced in accordance with the national standard. It is intended for food storage only, not for storage of blood, medicine and biological products.
- To prevent risk of fire, keep the appliance away from petrol or any other inflammables.
- To prevent risk of electromagnetic interference or other accidents, do not place a microwave oven on top of the refrigerator or use any electric appliance inside the refrigerator.
- Do not allow children to play with or near the appliance.
- Do not splash water onto the appliance. Keep it away from places of high humidity that may have adverse effect on the electric insulation performance.
- This appliance is designed to be used in ambient temperatures between 10 and 43°C. Use outside of this range may cause the appliance to fail.

Control Panel

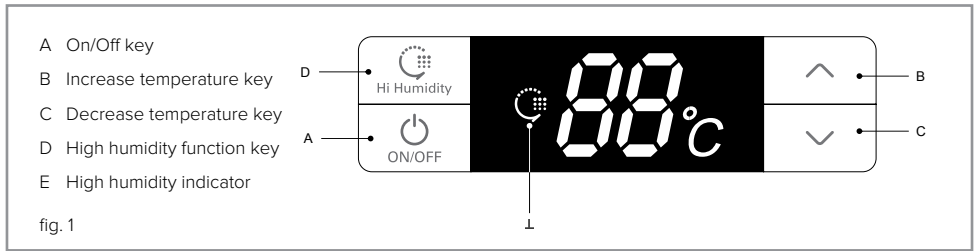

Switching the fridge on and off

To switch on the fridge for the first time, press and hold the On/Off key (A) for three seconds. The fridge will beep twice, and will run at the factory preset temperature of 5°. To switch the fridge off, press and hold the On/Off key for three seconds.

Setting the temperature

Press the increase or decrease temperature keys (B & C) to select the required temperature between 2° and 8°. Once the required temperature is shown on the display, the temperature will set after five seconds' delay and the fridge will beep twice to confirm the setting.

The fridge will take some time to adjust to the new settings. This will depend on the difference between the old and new settings, the ambient temperature, the amount of food in the fridge and the number of times the door is opened.

High humidity function

The fridge is equipped with a high humidity function which can prolong the life of some foods. To switch on the high humidity function, press and hold the high humidity key for three seconds. The

high humidity indicator will show on the display and the fridge will beep twice to confirm the setting. To switch the high humidity function off, press and hold the high humidity key for three seconds. The high humidity indicator on the display will switch off and the fridge will beep twice to confirm the setting.

Please note:

The temperature will show on the display for 30 seconds after the door has been opened, or a key has been pressed on the control panel before switching off automatically. To switch the display on, press any key.

In the event of a power failure, the fridge temperature settings will be restored to the programmed levels when the power returns.

Over temperature alarm

The fridge is equipped with an over temperature alarm to warn when the temperature in the fridge has been over 15° for six hours or more. The fridge will beep ten times every thirty minutes until the fridge temperature is below 10°, and the fault code E9 will show on the display. Press any key to switch the alarm off. E9 will continue to show on the display until the fault is resolved.

Defrosting the Fridge

The fridge is self-defrosting. The defrosted water is collected in the evaporating tray at the back of the appliance.

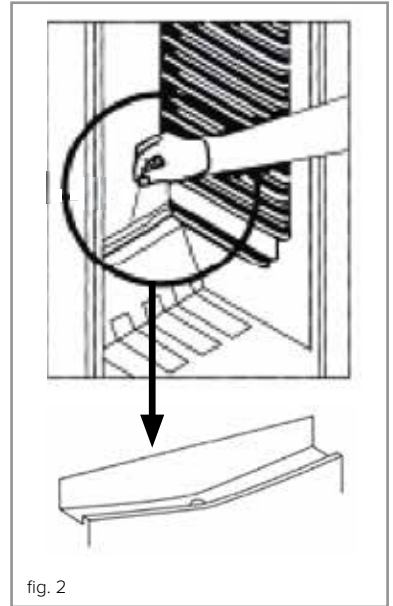

Adjusting the shelves

The fridge shelves can be moved according to the storage requirements within the fridge section.

To move the shelf, lift up the front section and then pull it outwards. To replace, slide the shelf back into the slot, and then lower the front section.

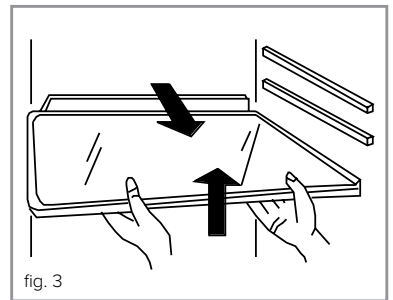

Care and Cleaning

Always disconnect the appliance from the power supply before any cleaning or maintenance.

- The refrigerator should be cleaned using a solution of bicarbonate of soda and lukewarm water.
- Do not use abrasive products or detergents. After washing, rinse and dry thoroughly.
- Clean the shelves and balconies separately by hand using soap and water. Do not put them in the dishwasher.
- Once cleaning is complete, reconnect the mains power supply.
- If the appliance is not used for prolonged periods of time or in the event of a prolonged power cut unplug and clean the appliance. The doors should be left slightly open to prevent the formation of mildew and smell.
- The door seal should be cleaned periodically.
- Clean the control panel with a dry cloth.
- Fingerprints are easily left on the exterior of this appliance. Use a dry towel to clean them off.
- Periodically dust the back and underneath of the refrigerator.
- If food products come into contact with the refrigerator's exterior surface, we recommend that you clean them off immediately.
- When disposing of this appliance, remove the door seal to avoid accidental entrapment.
- Please remove the door, door seal and shelves before disposal of the old appliance and put them away in a safe place to prevent children from being entrapped.

Troubleshooting

If you have any problems with your appliance, you should check the troubleshooting prior to calling CDA Customer Care to prevent unnecessary service calls and potential cost.

The appliance is not working

- Check there is power to the appliance:
- The house fuses are intact and the fuse in the plug has not blown.
- The thermostat is not set to 0 (off position).
- The plug socket is functioning fine. To check this, plug another electrical appliance in to see if the socket is working.
- The temperature of the room is adequate (16°C or above).

The appliance is working, but not very well

- The appliance is not overloaded.
- The thermostat is set to an appropriate temperature.
- The door is closing properly.
- The cooling system at the rear of the appliance is clean and free of dust, and not touching the rear wall.
- There is enough ventilation at the side and rear walls.
- The temperature of the room is adequate (16°C or above).

The appliance is noisy

- The appliance is level and stable.
- The side and rear walls are clear, and there is nothing resting on the appliance.
- The cooling gas in the refrigerator will make a slight bubbling noise, even when the compressor is not running.

There is water in the lower part of the refrigerator compartment

- The drain hole in the channel at the back of the compartment is clear.

Please note:

The LED lighting cannot be replaced without a service call. If the light fails, contact CDA Customer Care.

Error Codes

The display will show error codes if there is a fault with the appliance. These are detailed below.

Before calling CDA Customer Care, take note of the error code as this will help when attempting to resolve the problem.

Error Code	Fault Description
E1	Fridge freezer temperature failure
E4	Cooling defrosting sensor failure
E6	Communication failure
E7	Ambient temperature sensor failure
E9	High temperature warning
EC	PCB failure

Installation And Ventilation

This appliance must never be installed close to heat sources i.e. heating elements, cookers or in damp places

The diagram shows the ventilation requirements for your product.

Failure to provide adequate ventilation can lead to increased running costs and premature failure and may invalidate the warranty provided with the product.

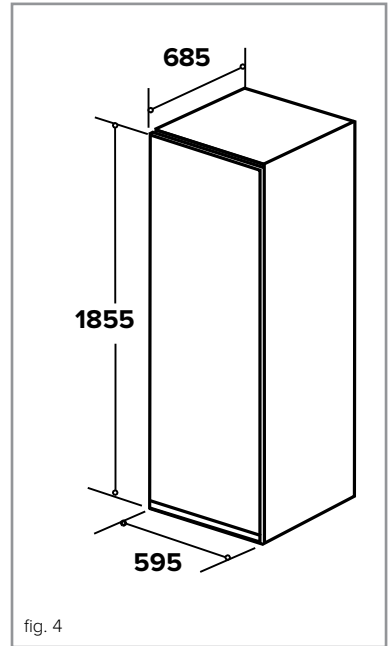

- Ensure ventilation openings are kept clear.
- Do not use a multi-purpose socket alongside other appliances.
- Do not tilt the fridge beyond 45°
- Do not exert excessive pressure on the appliance.
- Place the refrigerator in a well-ventilated position, away from heat sources, damp and direct sunlight.
- Ensure that a gap of no less than 30cm is left above the appliance and that the gap around the outside is no less than 10cm to allow the door to open fully.
- If the appliance is to be installed enclosed between units, please ensure a 50mm gap above the appliance or a 100mm gap at the rear of the appliance to the ceiling or any furniture above.

Reversing the Door

We recommend you seek the help of another individual to support the doors whilst performing this operation.

1. Carefully remove the two hinge cover plates and two cover caps from the control panel.

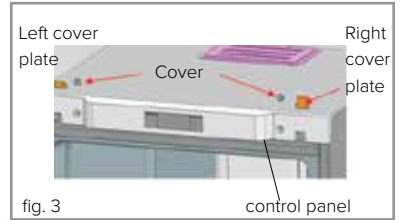

2. Remove the control panel, ensuring that the wires are not damaged. We recommend you secure the control panel with masking tape to the top of the fridge whilst it is detached.

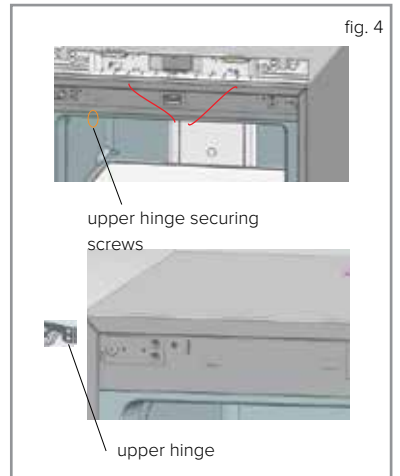

3. Remove the screws securing the upper hinge whilst supporting the door. Lift the upper hinge and door away and place the door safely to prevent damage.

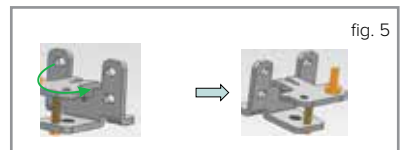

4. Remove the upper hinge from the door.

5. Remove the third hinge plate securing screw and relocate on the

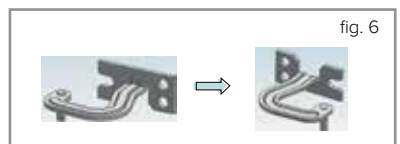

opposite side, leaving the screwhead approximately 3mm proud of the appliance.

6. Remove the lower hinge and reposition the lower hinge pin as shown in figure 5.

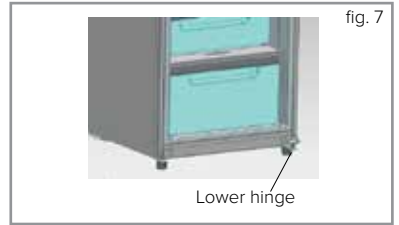

7. Reposition the lower hinge on the opposite side as shown in fig 7.



8. Reverse the upper hinge pin as shown in fig 6.

9. Locate the door on the lower hinge pin, then locate the upper hinge pin in the door.

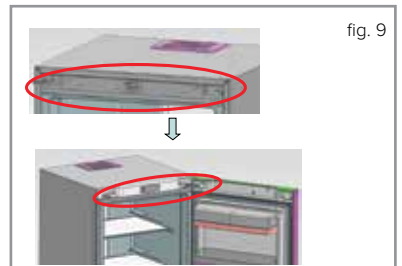

10. Slot the upper hinge into the locating screw on the appliance and then secure with the two screws removed in step 3.

11. Carefully refit the control panel, ensuring there are no trapped wires.

12. Replace the cover caps and hinge cover plates.

Electrical Information

Warning! This appliance must be earthed.

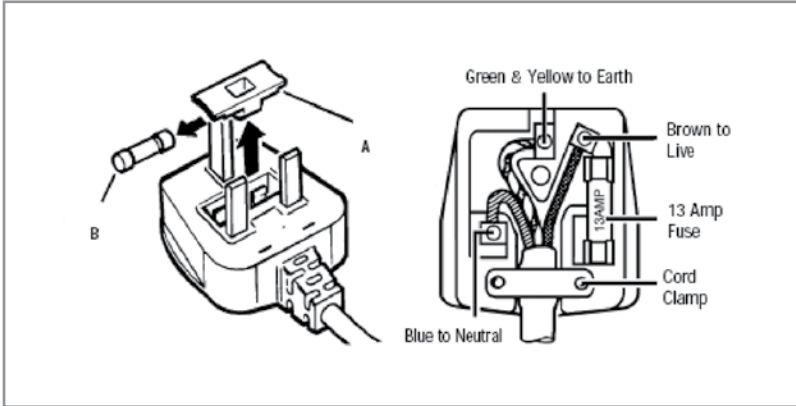

The mains lead of this appliance has been fitted with a BS 1363A 13 amp fused plug. To change a fuse in this type of plug, follow the steps below:

1. Remove the fuse cover and fuse.
2. Fit replacement 13A fuse, ASTA approved to BS 1362 type, into the fuse cover.
3. Replace fuse cover.

Important: Do not use the appliance without the fuse cover in position.

How to connect an alternative plug

If the fitted plug is not suitable for your socket outlet, then it should be cut off and disposed of safely to prevent the risk of electric shock. A suitable alternative plug of at least 13 Amp rating to BS 1363 should be used.

As the colours of the wires in the mains lead of this appliance may not correspond with the coloured markings identifying the terminals in your plug, proceed as follows:-

- The wire which is coloured GREEN and YELLOW must be connected to the terminal which is marked with letter (E) or by the Earth symbol or coloured GREEN and YELLOW.
- The wire which is coloured BLUE must be connected to the terminal which is marked with the letter (N), or coloured BLACK.
- The wire which is coloured BROWN must be connected to the terminal which is marked with the letter (L) or coloured RED.

If in doubt regarding the electrical connection of this appliance, consult a qualified electrician. Do not shorten the supply cable, the appliance may require removing for servicing.

N.B. Ensure that the plug socket is situated in an easily accessible place.

If the power supply cord is damaged, it must be replaced by a CDA authorised agent.

NOTES

NOTES



Please contact our Customer Care Department for Service on the details below

Customer Care Department • The CDA Group Ltd. • Harby Road • Langar • Nottinghamshire • NG13 9HY
T : 01949 862 012 F : 01949 862 003 E : service@cda.eu W : www.cda.eu