



PC87 American Style Double Door Fridge Freezer

Manual for Installation, Use and Maintenance

|C|D|A|

Important

The CDA Group Ltd cannot be held responsible for injuries or losses caused by incorrect use or installation of this product. Please note that CDA reserve the right to invalidate the guarantee supplied with this product following incorrect installation or misuse of the appliance.

This appliance is not designed to be used by people (including children) with reduced physical, sensorial or mental capacity, or who lack experience or knowledge about it, unless they have had supervision or instructions on how to use the appliance by someone who is responsible for their safety.

Under no circumstances should any external covers be removed for servicing or maintenance except by suitably qualified personnel.

Appliance information:

Please enter the details on the appliance rating plate below for reference, to assist CDA Customer Care in the event of a fault with your appliance and to register your appliance for guarantee purposes.

Appliance Model

Serial Number

CE Declarations of Conformity:

This appliance has been designed, constructed and marketed in compliance with safety requirements of EEC Directive 2006/95/EEC (Low voltage) and requirements of EMC Directive 2004/108/EEC.

This appliance has been manufactured to the strictest standards and complies with all applicable legislation, including Electrical safety (LVD) and Electromagnetic interference compatibility (EMC). Parts intended to come into contact with food conform to EEC/89/109.4

IMPORTANT INFORMATION FOR CORRECT DISPOSAL OF THE PRODUCT IN ACCORDANCE WITH EC DIRECTIVE 2002/96/EC.

At the end of its working life, the product must not be disposed of as urban waste. The refrigeration system contains insulating gases and refrigerants, which require specialised waste disposal. The valuable materials contained in this appliance can be recycle. It must be taken to a special local authority differentiated waste collection centre or to a dealer providing this service.

Before disposing of an old appliance, remove the latch or bolt lock to avoid the risk of child entrapment.

Disposing of a household appliance separately avoids possible negative consequences for the environment and health deriving from inappropriate disposal and enables the constituent materials to be recovered to obtain significant savings in energy and resources. As a reminder of the need to dispose of household appliances separately, the product is marked with a crossed-out wheeled dustbin. 



Important

- Never store inflammable or explosive items and strong corrosive acids or alkalis in the appliance.
- This is a household appliance, which is produced in accordance with the national standard. It is intended for food storage only, not for storage of blood, medicine and biological products.
- To prevent risk of fire, keep the appliance away from petrol or any other inflammables.
- To prevent risk of electromagnetic interference or other accidents, do not place a microwave oven on top of the refrigerator or use any electric appliance inside the refrigerator.
- Do not allow children to play with or near the appliance.
- The internal surface of freezer compartment is very cold when the appliance is running. Do not touch the surface especially when hands are wet.
- Do not splash water onto the appliance. Keep it away from places of high humidity that may have adverse effect on the electric insulation performance.
- This appliance is designed to be used in ambient temperatures between 16 and 38°C. Use outside of this range may cause the appliance to fail.

In the event of a power failure, leave the door closed as much as possible to maintain the internal working temperature.

Should the power failure continue for a prolonged period, you should take steps to protect the contents of the appliance against a rise in temperature. The appliance will remember the selected temperature settings and revert to these settings once the power is restored.

Before First Use

You must allow the fridge to settle for at least twenty four hours prior to switching the power on.

It is recommended that you clean the interior of the appliance prior to first use, using a solution of bicarbonate of soda and warm water and then thoroughly dry the interior.

The fridge may have an odour to it at first use. This will disappear as the appliance cools.

Do not load the appliance with food until it reaches the required temperature.

Please note:

The appliance will work continuously until it comes down to the correct temperature.

If the appliance is switched off, you should allow five minutes before switching it on again to prevent unnecessary damage to the compressor.

The fridge shelves can be moved according to storage requirements.

To move the shelf, tilt the shelf upwards and then unhook the shelf at the top. To replace, slot the top of the shelf into the housing, then lower the front section to locate the lower supports in place.

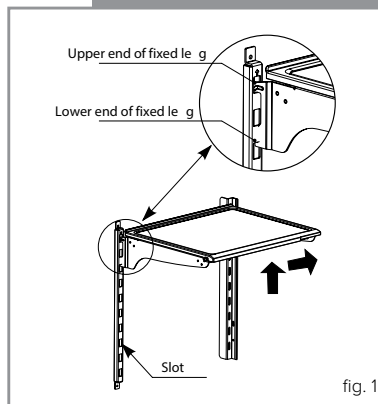

fig. 1

Use

Fridge

- Never put liquids in the refrigerator uncovered.
- Never put hot foods in the refrigerator. Warm food should be allowed to cool to room temperature before being put into the refrigerator.
- Nothing should rest against the rear wall of the refrigerator, as this will cause frost and possible condensation problems which will be difficult to remove.
- Make sure food is clean and any extra water is wiped away before putting into the fridge.
- Wrap or cover food before putting into the fridge. This will help prevent the loss of moisture, keep food fresh and avoid unpleasant odours.
- Sort foods prior to storing. Any foods to be used soon should be stored at the front of the shelf to prevent deterioration caused by the door being open for prolonged periods.
- Do not overfill the fridge. There should be sufficient space between the foods to allow the cool air to circulate.
- Thawing frozen foods in the fridge compartment will help to keep the temperature low and save energy.

Freezer

- The freezer compartments are designed to store only frozen food.
- Never put hot or warm foods in the freezer, allow them to cool fully before putting them into the freezer.
- Follow the instructions on the food packaging for storage of frozen food. If no information is provided, foods should not be stored for more than three months after the purchase date.
- Store food in small packages (ideally less than 2.5kg). This reduces the freezing time and improves the quality of the food after thawing.
- Wrap food before putting into the freezer. To stop the wrapping sticking together, ensure it is dry.
- Label the food before freezing with information including type of food and dates of storage and expiry.
- Once food is thawed, it must not be refrozen unless it has been completely cooked. Only defrost as much food as is required to prevent wastage.
- Bottled or canned drinks should not be stored in the freezer compartments as they could explode.
- Check the rating plate to confirm the maximum amount of fresh food that can be frozen within a 24 hour period.
- Do not attempt to freeze more than the maximum amount.
- To freeze fresh food more quickly, switch on the quick freeze function a few hours prior to placing the food in the freezer.
- Do not use the super freeze function for more than 48 hours. Use over the recommended time will place unnecessary strain on the refrigeration system.

Control Panel



Setting the fridge temperature

Touch the **TEMP ZONE** key so that **REF TEMP** lights up. Then touch **+** or **-** to select the required temperature between 2° and 8°. When the required temperature shows on the control panel, touch the **TEMP ZONE** key to confirm the selection.

Setting the freezer temperature

Touch the **TEMP ZONE** key so that **FRZ TEMP** lights up. Then touch **+** or **-** to select the required temperature between -16° and -24°. When the required temperature shows on the control panel, touch the **TEMP ZONE** key to confirm the selection.

Super freeze function

The super freeze function can be used to freeze large quantities of fresh food as quickly as possible. This function will switch off automatically for convenience. For best results, switch the super freeze function on 12 hours prior to introducing large quantities of food to be frozen.

To switch on the super freeze function, touch and hold the **SUPER COOL** key for three seconds. The super freeze symbol will light up on the display and the freezer temperature display will show -24°.

To switch off the super freeze function before the preset duration is complete, touch and hold the **SUPER COOL** key for three seconds. The super freeze symbol will switch off on the display and the freezer temperature will return to the previous set temperature.



IMPORTANT Do not use the super freeze function for more than 48 hours

Fridge off function

This appliance is equipped with a vacation mode function, which will switch the fridge off, maintaining frozen food during a holiday without running the fridge as well.

To switch the fridge off, touch and hold the **ENERGY SAVING** key for three seconds. The display will show REF OFF and the fridge zone display will switch off.

To return to normal operation, touch and hold the **ENERGY SAVING** key for three seconds. REF OFF will switch off on the display and the fridge zone display will light up.

Super cool function

The super cool function can be used to maintain the fridge temperature when large quantities of fresh food are introduced into the fridge.

To switch on the super cool function, touch the **SUPER COOL** key. The super cool symbol will light up on the display and the fridge temperature display will show 2°.

To switch off the super cool function before the preset duration is complete, touch the **SUPER COOL** key. The super cool symbol will switch off on the display and the fridge temperature will return to the previous set temperature.

Energy saving mode

This model is equipped with an energy saving mode, which sets the freezer temperature to -15° and the fridge temperature to 7° to reducing energy consumption.

To switch on the energy saving function, touch the **ENERGY SAVING** key. The energy saving symbol will light up on the display, the freezer temperature will show -15° and the fridge temperature display will show 7°.

To switch off the super cool function before the preset duration is complete, touch the **SUPER COOL** key. The super cool symbol will switch off on the display and the fridge temperature will return to the previous set temperature.

To switch off the energy saving mode, touch the **ENERGY SAVING** key again. The energy saving mode symbol will no longer show on the display and the fridge and freezer temperatures will return to the previous set temperatures.

Child lock

The fridge is equipped with a child lock to prevent accidental reprogramming of the fridge. The child lock switches on automatically 30 seconds after the last key touch.

To switch the child lock on or off, touch and hold the **CHILD LOCK** key for three seconds. When the lock is on, the child lock symbol will show on the display.

Installation and Ventilation

This appliance must never be installed close to heat sources i.e. heating elements, cookers or in damp places.

Failure to provide adequate ventilation can lead to increased running costs and premature failure and may invalidate the warranty provided with the product.

- Ensure ventilation openings are kept clear.
- Do not use a multi-purpose socket alongside other appliances.
- Do not tilt the fridge beyond 45°.
- Do not exert excessive pressure on the appliance.
- Place the refrigerator in a well-ventilated position, away from heat sources, damp and direct sunlight.
- Ensure that a gap of no less than 10cm is left above the appliance and that the gap around the outside is no less than 10cm.

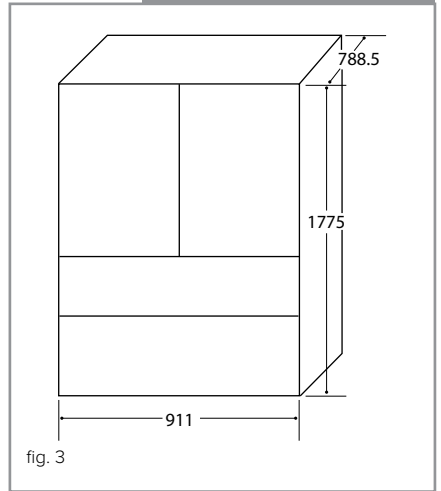



Care and Cleaning

IMPORTANT: Always disconnect the appliance from the power before any cleaning or maintenance.

- The refrigerator and freezer sections should be cleaned using a solution of bicarbonate of soda and lukewarm water.
- Do not use abrasive products or detergents. After washing, rinse and dry thoroughly.
- Clean the shelves and balconies separately by hand using soap and water. Do not put them in the dishwasher.
- The evaporating tray and water drain hole (at the back of the refrigerator compartment) should be cleaned periodically to prevent the defrosted water from collecting inside the refrigerator compartment. The drainplug can be used to clear the drain hole.
- Once cleaning is complete, then reconnect the power.
- If the appliance is not used for prolonged periods of time, unplug and clean the appliance. The doors should be left slightly open to prevent the formation of mildew and smell.

This appliance must never be installed close to heat sources, e.g. heating elements, cookers or in damp places.

- The plug should be fully accessible at all times.
- To ensure the appliance is level, you should use the height adjustable feet at the front of the appliance.
- The cooling system at the rear of the appliance must not touch the rear wall.
- The appliance must be installed with adequate ventilation. Ensure that there is 10 cm clearance above the appliance, and that there is space between the rear of the appliance and the wall.

Troubleshooting

If you have any problems with your appliance, you should check the troubleshooting prior to calling CDA Customer Care to prevent unnecessary service calls and potential cost.

If the appliance is not working

- Check there is power to the appliance:
- The house fuses are intact and the fuse in the plug has not blown.
- The plug socket is functioning fine. To check this, plug another electrical appliance in to see if the socket is working.

The appliance is working, but not very well

- The appliance is not overloaded.
- The thermostat is set to an appropriate temperature.
- The doors are closing properly.
- The cooling system at the rear of the appliance is clean and free of dust, and not touching the rear wall.
- There is enough ventilation at the side and rear walls.

The appliance is noisy

- The appliance is level and stable.
- The side and rear walls are clear, and there is nothing resting on the appliance.
- The cooling gas in the refrigerator will make a slight bubbling noise, even when the compressor is not running.
- It is normal for the ice and water dispenser to make noise during the ice making process and dispensing. This does not constitute a fault.

There is water in the lower part of the refrigerator compartment

- The drain hole in the channel at the back of the compartment is clear

Please note:

The LED lighting cannot be replaced without a service call. If the light fails, contact CDA Customer Care.

Electrical Information

Warning! This appliance must be earthed.

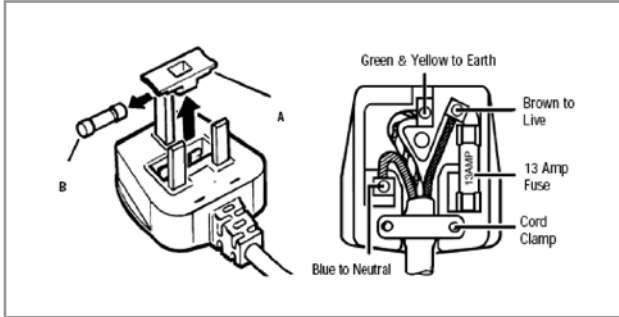

The mains lead of this appliance has been fitted with a BS 1363A 13 Amp fused plug. To change a fuse in this type of plug, follow the steps below:

1. Remove the fuse cover and fuse.
2. Fit replacement 13A fuse, ASTA approved to BS 1362 type, into the fuse cover.
3. Replace fuse cover.

Important: Do not use the appliance without the fuse cover in position.

How to connect an alternative plug

If the fitted plug is not suitable for your socket outlet, then it should be cut off and disposed of safely to avoid possible shock hazard. A suitable alternative plug of at least 13 Amp rating to BS 1363 should be used.

As the colours of the wires in the mains lead of this appliance may not correspond with the coloured markings identifying the terminals in your plug, proceed as follows:-

- The wire which is coloured GREEN and YELLOW must be connected to the terminal which is marked with letter (E) or by the Earth symbol \perp or coloured GREEN and YELLOW.
- The wire which is coloured BLUE must be connected to the terminal which is marked with the letter (N) or coloured BLACK.
- The wire which is coloured BROWN must be connected to the terminal which is marked with the letter (L) or coloured RED.

If in doubt regarding the electrical connection of this appliance, consult a qualified electrician. Do not shorten the supply cable, the appliance may require removing for servicing.

N.B. Ensure that the plug socket is situated in an easily accessible place.

If the power supply cord is damaged, it must be replaced by a CDA authorised agent.



To contact our Customer Care Department, or for Service,
please contact us on the details below.