

3C9 Extractors

Manual for Installation, Use and Maintenance

|C|D|A|

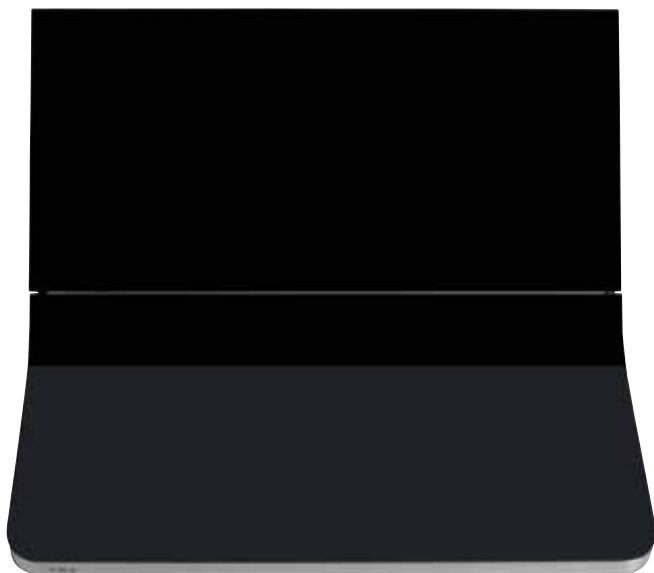

Important

The manufacturer cannot be held responsible for injuries or losses caused by incorrect use or installation of this product. Please note that the manufacturer reserves the right to invalidate the guarantee supplied with this product following incorrect installation or misuse of the appliance or use in a commercial environment.

This appliance is not designed to be used by people (including children) with reduced physical, sensorial or mental capacity, or who lack experience or knowledge about it, unless they have had supervision or instructions on how to use the appliance by someone who is responsible for their safety.

Under no circumstances should any external covers be removed for servicing or maintenance except by suitably qualified personnel.

Appliance information:

Please enter the details on the appliance rating plate below for reference, to assist CDA Customer Care in the event of a fault with your appliance and to register your appliance for guarantee purposes.

Appliance Model

Serial Number

CE Declarations of Conformity:

This appliance has been manufactured to the strictest standards and complies with all applicable legislation, including Gas safety, Electrical safety (LVD) and Electromagnetic interference compatibility (EMC).

IMPORTANT INFORMATION FOR CORRECT DISPOSAL OF THE PRODUCT IN ACCORDANCE WITH EC DIRECTIVE 2002/96/EC.

At the end of its working life, the product must be taken to a special local authority waste collection centre or to a dealer providing appliance recycling services. Disposing of a household appliance separately avoids possible negative consequences for the environment and health. It also enables the constituent materials to be recovered, saving both energy and resources. As a reminder of the need to dispose of household appliances separately, the product is marked with a crossed-out wheeled dustbin 

Please note:

- Under no circumstances should the extractor be connected to any gas ventilation system, flue system or hot air ducting system.
- Do not vent the extractor into an attic or loft space.
- Only house the extractor in rooms with adequate ventilation. Remember that the extractor is powerful and whatever air is extracted needs to be replaced.
- Do not tile the extractor in. It should be removable for service or maintenance.
- Do not use silicone sealant to secure the hood to the wall.
- You must be able to isolate the extractor from the mains electrical supply after installation.
- Steam cleaners must not be used when cleaning this appliance.
- The performance of your extractor will vary depending on a number of factors. These include: type of extraction, length of ducting, room volume, ventilation available and cleanliness of the filters.

Using your Extractor

For best performance, you should switch on the extractor 15 minutes before starting to cook and leave it to run for approximately 15 minutes after the end of cooking.

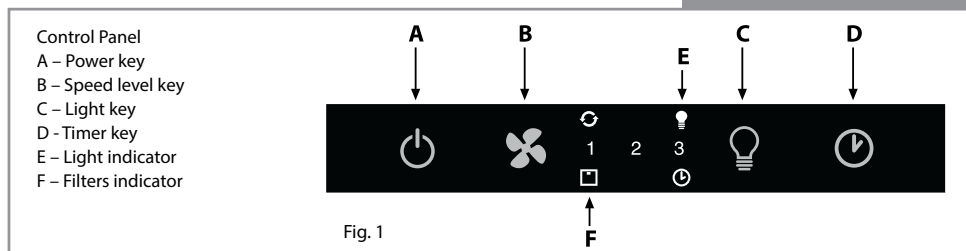

To switch on the extractor and set the speed level

- Touch key A. The appliance will switch on at the first speed level.
- To increase the speed level touch key B. The speed cycles through first, second and third speed levels, and the relevant number indicator will show on the centre of the display.
- To switch the extractor off, touch key A.

The extractor lights

- To switch the lights on touch key C. The extractor lights will cycle through three light settings (high, medium, low, off) with each touch of the key. The light indicator will show on the centre of the display when the lights are on.

The intensive function

- The extractor is equipped with an intensive function which runs for ten minutes before returning to the previous selected speed level.
- To activate the intensive function, touch and hold key B at any speed level for approximately five seconds. The 3 indicator on the centre of the display will flash whilst the intensive function is on.
- To cancel the intensive function, touch the speed level key and the extractor will return to the previous speed level.

The timer

- The extractor is equipped with a timer that allows the extractor to run for 15 minutes before switching off automatically.
- To activate the timer, touch key D. The timer indicator will show on the centre of the display when the timer is on.

Please note

The timer cannot be activated when the intensive function is on.

The clean air function

- The extractor is equipped with a clean air function that switches on the motor for ten minutes every hour at speed level one.
- To activate the clean air function, touch key A for five seconds when the appliance is off. When the motor is running, the light indicator will flash and the first speed indicator will light up. For the remaining 50 minutes, the light indicator will flash.
- To cancel the clean air function, touch any key except the light key.

Using your Remote Control

Synchronising your remote with the extractor

1. Whilst the appliance is off, touch the light key on the extractor for approximately five seconds until the indicator light begins to flash, as shown in figure 2.
2. Turn the top section of the remote control until the indicator light on the extractor stops flashing.

In the event of any problems, repeat the steps above.

To set the motor speed

- Turn the top section of the remote control so the indicator is at the required speed level, as shown in figure 3.
- To select the intensive speed level, press the remote control in for two seconds at positions one, two or three, as shown in figure 4.

To turn on the light

- Press the remote control in to switch on the light to the highest level, as shown in figure 5.
- To cycle through the light settings (high, medium, low, off) press the remote control in repeatedly.

To change the battery

- The battery will last for approximately 12 months, depending on usage.
- To change the battery, remove the lid from the remote control, as shown in figure 6.
- Then remove the battery by applying pressure to the edge, as shown in figure 7.
- Replace with a 3 Volt 5004LC / CR 2032 battery.

Please note:

The remote control will work up to five metres away from the extractor.
The base of the remote control is magnetic so can be attached to ferrous surfaces.

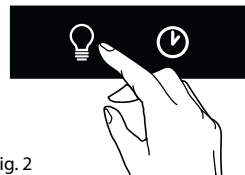

Fig. 2

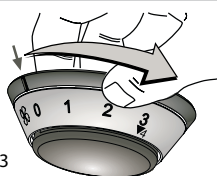

Fig. 3

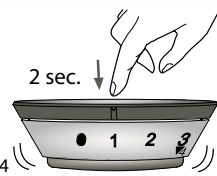

Fig. 4

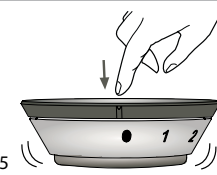

Fig. 5



Fig. 6

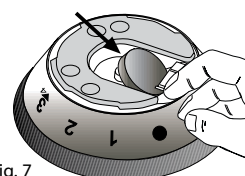

Fig. 7

Care and Maintenance

IMPORTANT : DO NOT PERFORM MAINTENANCE OR CLEANING OF THE EXTRACTOR WITHOUT FIRST SWITCHING OFF THE ELECTRICITY SUPPLY.

Cleaning

You should use a nonabrasive cleaner. Any abrasive cleaner (including Cif) will scratch the surface and could erase the control panel markings.

You can clean your extractor effectively by simply using a dilute solution of water and mild detergent and drying to a shine with a clean cloth.

Cleaning the grease filter

The grease filter should be kept clean to minimise the risk of fire.

After 30 hours of use, the filters indicator light will switch on to indicate that the grease filters must be washed. you should remove and clean the grease filter with hot soapy water. You can also wash the grease filter in a dishwasher, ensuring that you place it in an upright position to prevent damage from other items in the dishwasher. After rinsing and drying, replace the filter. After the grease filter has been replaced, the electronic memory must be reset by touching the speed level key for approximately five seconds, until the filters indicator light switches off.

To remove the grease filter follow the steps below:

Pull open the handle on the grease filter as shown in fig. 8. It will release at the handle side. Then lower the grease filter to remove it completely.

To replace the grease filter, repeat the steps in reverse.

Please note:

Cleaning the grease filter in the dishwasher may lead to discolouration. This is normal and does not constitute a fault with the appliance.

Changing the charcoal filter (re-circulating only)

After 120 hours of use, the filters indicator light will flash to indicate that the charcoal filters must be replaced (if present). After the charcoal filter has been replaced, the electronic memory must be reset by touching the speed level key for approximately five seconds, until the filters indicator light switches off.

To attach a new charcoal filter, first open the cover panel as shown in figure 8. Then offer up the charcoal filter to the side of the motor as shown in figure 4 and turn it clockwise until it locks into place. Repeat with the other charcoal filter on the other side of the motor. Then close the cover panel.

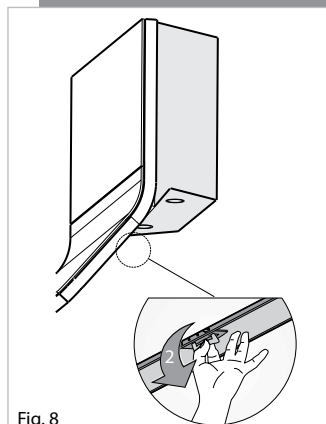

Fig. 8

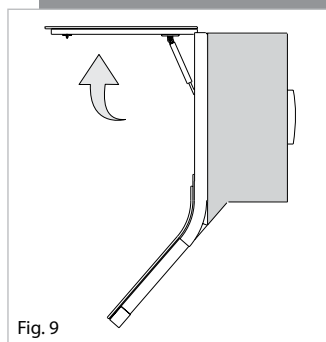

Fig. 9

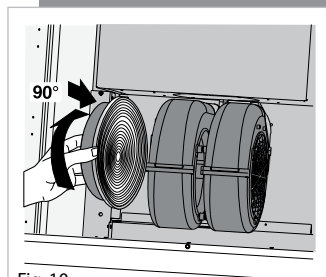

Fig. 10

Changing the Light

IMPORTANT: DO NOT PERFORM MAINTENANCE OR CLEANING OF THE EXTRACTOR WITHOUT FIRST SWITCHING OFF THE ELECTRICITY SUPPLY.

DO NOT CHANGE THE LIGHT BULB IMMEDIATELY AFTER USE AS THE BULB WILL BE HOT. ALLOW IT TO COOL BEFORE REMOVING IT.

Carefully prise the bulb from the extractor using a small, flat-bladed screwdriver. Refit the new bulb taking care not to touch the glass (Fingerprints will lead to premature failure of the bulb).

Do not touch bulbs or adjacent areas during or straight after prolonged use of the lights.

The light is designed for use during cooking and not for general room illumination. Extended use of the light can reduce the life span of the bulb.

Bulb replacement is not covered by the guarantee.

Only use bulbs recommended for your extractor. Do not fit bulbs of a higher power rating.

Bulbs of a lower power rating may be adequate for use, generally last longer and use less energy.

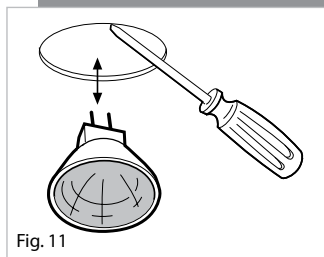

Fig. 11

Mains Electricity Connection

THIS APPLIANCE MUST BE CONNECTED TO THE MAINS SUPPLY BY A COMPETENT PERSON, USING FIXED WIRING VIA A DOUBLE POLE SWITCHED FUSE SPUR OUTLET AND PROTECTED BY A 3A FUSE.

We recommend that the appliance is connected by a qualified electrician, who is a member of the N.I.C.E.I.C. and who will comply with the I.E.E. and local regulations.

The wires in the mains lead of this appliance are coloured in accordance with the following code:

Green & Yellow = Earth, Blue = Neutral, Brown = Live.

As the colours of the wires in the mains lead for the appliance may not correspond with the coloured markings identifying the terminals connecting to the fuse spur, proceed as follows:

- The wire which is coloured green and yellow must be connected to the terminal marked E (Earth), or coloured green.
- The wire which is coloured blue must be connected to the terminal marked N (Neutral), or coloured black.
- The wire which is coloured brown must be connected to the terminal marked L (Live), or coloured red.

Note: Use a 3A Fuse

Assembly and electrical connection should be carried out by specialised personnel.

When installing this product we recommend you seek the help of another individual.

Electrical Information

Mains electrical voltage: 230 – 240Vac, 50Hz

Total rated power consumption:

290W

Troubleshooting

If your extractor is not working:

1. Check that the mains supply has not been switched off.
2. Check that the fuse in the spur has not blown.

DOUBLE POLE SWITCHED
FUSE SPUR OUTLET

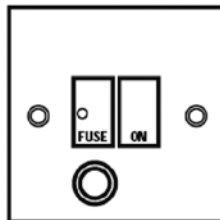

USE A 3 AMP FUSE

Installation

Your extractor can be used to filter and recycle the air within your kitchen, or to extract the air outside. When extracting air to the outside, the unit can be vented as shown in the diagram below. Note that we recommend the use of ducting with a diameter of 150mm. Ducting with diameters of 100mm or 120mm may be used, but performance will be reduced.

Note that this product is heavy and should be installed by two persons

The clearance between the underside of the extractor and any hob underneath must be equal to or exceed 750mm (For electric hobs, this height can be reduced to 650mm, but is not recommended)

IN THE ABSENCE OF ANY INSTRUCTIONS SUPPLIED WITH THE HOB, THE MINIMUM DISTANCE BETWEEN THE HOB AND EXTRACTOR MUST BE AT LEAST 760mm

Fitting your extractor to the wall:

Before commencing, remove both the grease filters as shown in figure 8 and the top cover (Fig 13).

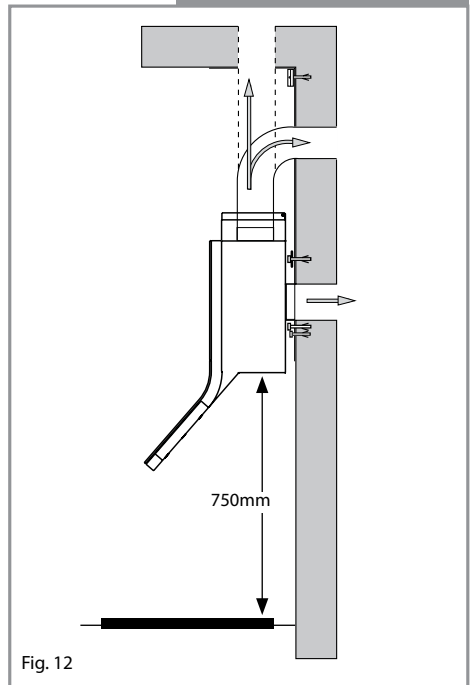

Fig. 12

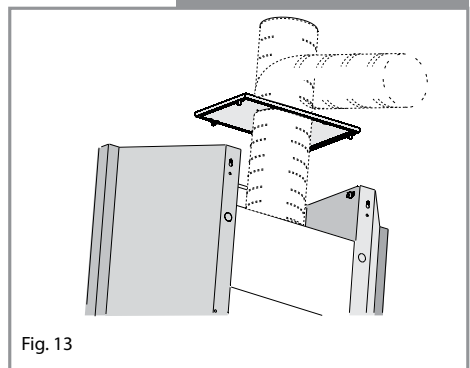

Fig. 13

Installation

Remove the top cover (E) and vent outlet (M), as shown in figure 15.

Using the provided template mark the positions of the four fixing holes on the wall, taking care to ensure that the bottom of the extractor is at least the same or greater than the clearance distance needed between the hob and extractor.

The wall plugs used must be suitable for the type of wall the extractor is to be fixed to. Insert the four plugs and fix two screws (K) into the upper plugs, leaving approx 5mm protruding.

Carefully lift the extractor and mount it on the two screws and secure them tightly.

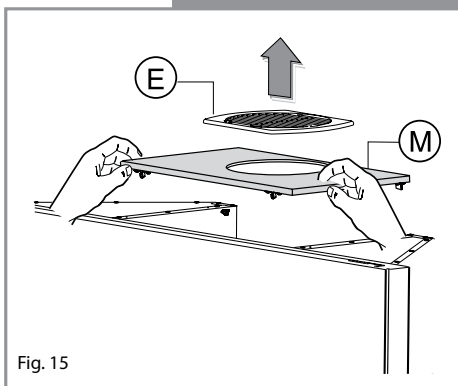

Fig. 15

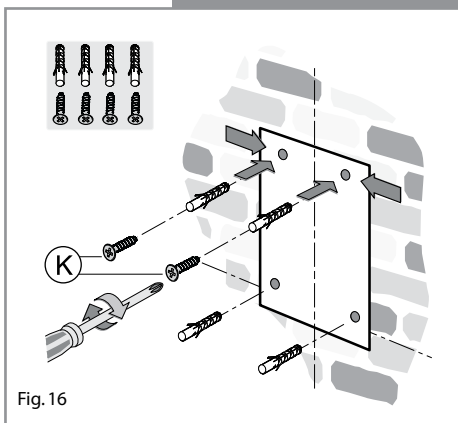

Fig. 16

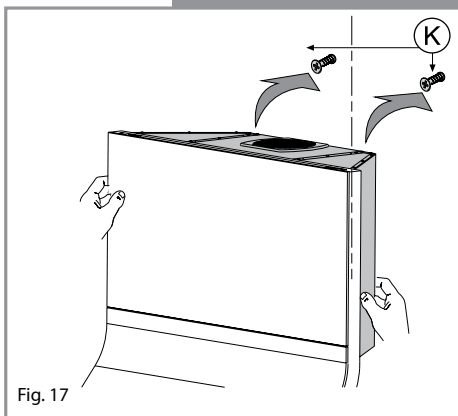

Fig. 17

Installation

Lift open the front top panel, as shown in figure 18.

Fit the remaining two screws to secure the extractor to the wall.

Note that it is recommended that you support the extractor until the unit is secured to the wall.

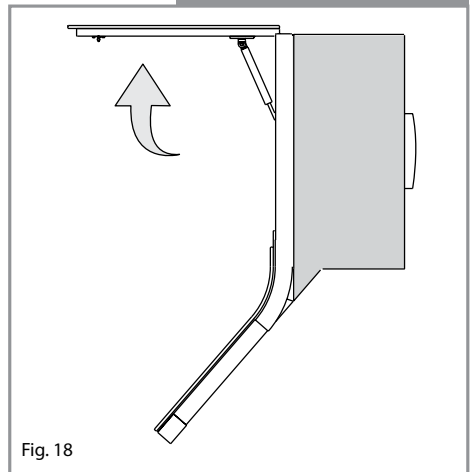

Fig. 18

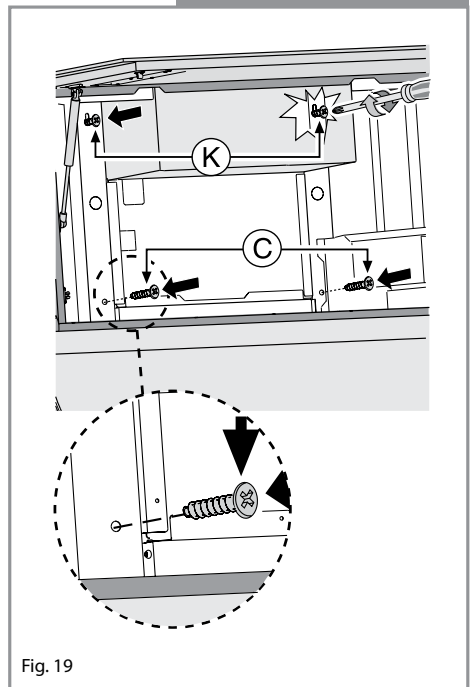

Fig. 19

Using the extractor as a recirculation device

Refit the top cover and grill as below before proceeding to fit the charcoal filter – Locate each filter onto the motor housing spigot and rotate to lock into position as shown in figure 20.

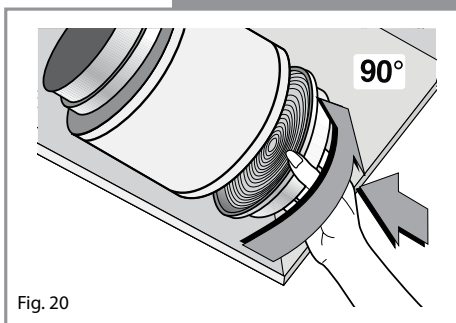

Fig. 20

Using the extractor as an extraction device

Feed the duct pipe through the top cover and fix it to the duct adapter ring. Connect the ring to the extractor and refit the top cover panel. Note that charcoal filters are not required when the unit is to be operating in this manner.

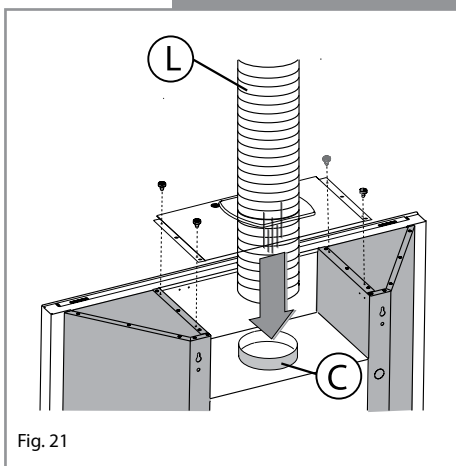

Fig. 21







Energy Efficiency Information

Attribute	Symbol	Value	Units
Model Identification		3c9	
Annual Energy Consumption	AEC_{Hood}	95.4	kWh
Time increase factor	f	1.4	
Fluid Dynamic Efficiency	FDE_{Hood}	16.7 (D)	
Energy Efficiency Index	EEL_{Hood}	87.8 (D)	
Measured airflow at Best Efficiency Point	Q_{BEP}	294.3	m^3/h
Measured Pressure at Best Efficiency Point	P_{BEP}	265.0	Pa
Maximum airflow	Q_{MAX}	362.0	m^3/h
Measured electric power at Best Efficiency Point	W_{BEP}	129.7	W
Nominal lighting power	WL	40.0	W
Average illumination of the lighting system on the cooking surface	E_{Middle}	200.0	Lux
Measured power consumption in standby	P_S	1.0	W
Measured power consumption off mode	P_O	NA	W
Sound power level	L_{WA}	52.0	dBA
Grease Filter Efficiency	GFE_{Hood}	45 (G)	%
Lamp efficiency	LE_{Hood}	5 (F)	%



To contact our Customer Care Department, or for Service,
please contact us on the details below.