



# PC70 American Style Fridge Freezer

**Manual for Installation, Use and Maintenance**



**|C|D|A|**

## Important

The CDA Group Ltd cannot be held responsible for injuries or losses caused by incorrect use or installation of this product. Please note that CDA reserve the right to invalidate the guarantee supplied with this product following incorrect installation or misuse of the appliance.

This appliance is not designed to be used by people (including children) with reduced physical, sensorial or mental capacity, or who lack experience or knowledge about it, unless they have had supervision or instructions on how to use the appliance by someone who is responsible for their safety.

Under no circumstances should any external covers be removed for servicing or maintenance except by suitably qualified personnel.

### Appliance information:

Please enter the details on the appliance rating plate below for reference, to assist CDA Customer Care in the event of a fault with your appliance and to register your appliance for guarantee purposes.

Appliance Model

Serial Number

### CE Declarations of Conformity:

This appliance has been designed, constructed and marketed in compliance with safety requirements of EEC Directive 2006/95/EEC (Low voltage) and requirements of EMC Directive 2004/108/EEC.

This appliance has been manufactured to the strictest standards and complies with all applicable legislation, including Electrical safety (LVD) and Electromagnetic interference compatibility (EMC). Parts intended to come into contact with food conform to EEC/89/109.4

### IMPORTANT INFORMATION FOR CORRECT DISPOSAL OF THE PRODUCT IN ACCORDANCE WITH EC DIRECTIVE 2002/96/EC.

At the end of its working life, the product must not be disposed of as urban waste. The refrigeration system contains insulating gases and refrigerants, which require specialised waste disposal. The valuable materials contained in this appliance can be recycle. It must be taken to a special local authority differentiated waste collection centre or to a dealer providing this service.

Before disposing of an old appliance, remove the latch or bolt lock to avoid the risk of child entrapment.

Disposing of a household appliance separately avoids possible negative consequences for the environment and health deriving from inappropriate disposal and enables the constituent materials to be recovered to obtain significant savings in energy and resources. As a reminder of the need to dispose of household appliances separately, the product is marked with a crossed-out wheeled dustbin. 



## Important

- Never store inflammable or explosive items and strong corrosive acids or alkalis in the appliance.
- This is a household appliance, which is produced in accordance with the national standard. It is intended for food storage only, not for storage of blood, medicine and biological products.
- To prevent risk of fire, keep the appliance away from petrol or any other inflammables.
- To prevent risk of electromagnetic interference or other accidents, do not place a microwave oven on top of the refrigerator or use any electric appliance inside the refrigerator.
- Do not allow children to play with or near the appliance.
- The internal surface of freezer compartment is very cold when the appliance is running. Do not touch the surface especially when hands are wet.
- Do not splash water onto the appliance. Keep it away from places of high humidity that may have adverse effect on the electric insulation performance.
- This appliance is designed to be used in ambient temperatures between 16 and 38°C. Use outside of this range may cause the appliance to fail.

In the event of a power failure, leave the door closed as much as possible to maintain the internal working temperature. Should the power failure continue for a prolonged period, you should take steps to protect the contents of the appliance against a rise in temperature. The appliance will remember the selected temperature settings and revert to these settings once the power is restored.

**IMPORTANT:** Remove the lid from the top of the ice dispenser inside the freezer door prior to first switching on the freezer.

On first use, the icemaker will begin working once the freezer has reached the required temperature. This can take up to 6 hours.

If ice will not be required, touch the ice off key on the control panel to switch off the ice maker.

On first connection, select the water option using the dispenser selection key on the control panel. Place a jug or other suitable container under the dispenser nozzle and push the switch for two to three minutes, or until water starts to dispense.

The pipes must be cleaned through on first use to remove any impurities in the system after installation. To do so, place a jug or other suitable container under the dispenser nozzle and push the switch to start the dispenser. Dispense water for approximately three minutes and ice for approximately one minute, and then dispose of the water and ice dispensed.

## Before First Use

**You must allow the fridge to settle for at least twenty four hours prior to switching the power on.**

It is recommended that you clean the interior of the appliance prior to first use, using a solution of bicarbonate of soda and warm water and then thoroughly dry the interior.

The fridge may have an odour to it at first use. This will disappear as the appliance cools.

Do not load the appliance with food until it reaches the required temperature.

### **Please note:**

The appliance will work continuously until it comes down to the correct temperature.

If the appliance is switched off, you should allow five minutes before switching it on again to prevent unnecessary damage to the compressor.

The fridge and freezer shelves can be moved according to storage requirements.

To move the shelf, pull the shelf outwards until the shelf stops (approximately one third out) then lift up the front section slightly and pull the shelf out. To replace, slide the shelf back into the slot, and then lower the front section before pushing fully back into position.

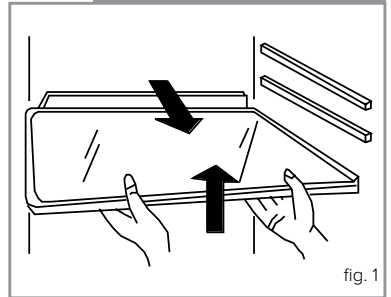

## Use

### Fridge

- Never put liquids in the refrigerator uncovered.
- Never put hot foods in the refrigerator. Warm food should be allowed to cool to room temperature before being put into the refrigerator.
- Nothing should rest against the rear wall of the refrigerator, as this will cause frost and possible condensation problems which will be difficult to remove.
- Make sure food is clean and any extra water is wiped away before putting into the fridge.
- Wrap or cover food before putting into the fridge. This will help prevent the loss of moisture, keep food fresh and avoid unpleasant odours.
- Sort foods prior to storing. Any foods to be used soon should be stored at the front of the shelf to prevent deterioration caused by the door being open for prolonged periods.
- Do not overfill the fridge. There should be sufficient space between the foods to allow the cool air to circulate.
- Thawing frozen foods in the fridge compartment will help to keep the temperature low and save energy.

### Freezer

- The freezer compartments are designed to store only frozen food.
- Never put hot or warm foods in the freezer, allow them to cool fully before putting them into the freezer.
- Follow the instructions on the food packaging for storage of frozen food. If no information is provided, foods should not be stored for more than three months after the purchase date.
- Store food in small packages (ideally less than 2.5kg). This reduces the freezing time and improves the quality of the food after thawing.
- Wrap food before putting into the freezer. To stop the wrapping sticking together, ensure it is dry.
- Label the food before freezing with information including type of food and dates of storage and expiry.
- Once food is thawed, it must not be refrozen unless it has been completely cooked. Only defrost as much food as is required to prevent wastage.
- Bottled or canned drinks should not be stored in the freezer compartments as they could explode.
- Check the rating plate to confirm the maximum amount of fresh food that can be frozen within a 24 hour period.
- Do not attempt to freeze more than the maximum amount.
- To freeze fresh food more quickly, switch on the quick freeze function a few hours prior to placing the food in the freezer.
- Do not use the quick freeze function for more than 48 hours. Use over the recommended time will place unnecessary strain on the refrigeration system.

## Control Panel

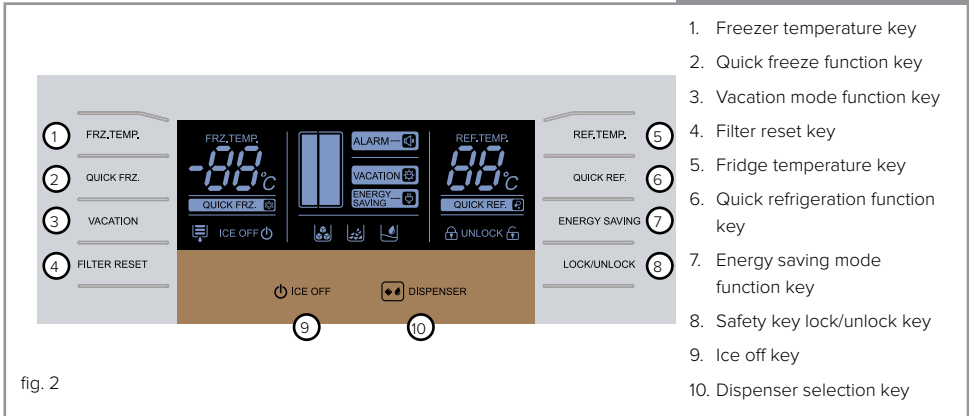

fig. 2

### Setting the freezer temperature

Touch the freezer temperature key (1). The freezer section and the freezer temperature on the display will flash. Then touch the freezer temperature key again. The temperature will cycle on the display with each touch of the key from -16° to -24° before returning to -16°.

Once the required temperature is shown on the display, the freezer temperature will set after five seconds' delay.

### Quick freeze function

The quick freeze function can be used to freeze large quantities of fresh food as quickly as possible. This function can be set for specific durations before switching off automatically for convenience. For best results, switch the quick freeze function on 12 hours prior to introducing large quantities of food to be frozen

To switch on the quick freeze function, touch the quick freeze function key (2). The quick freeze symbol on the display will flash and the freezer temperature display will show 6. Touch the quick freeze function key again to cycle on the display through the duration for the quick freeze function (6, 8, 12, 24, 48 hours or set freezer temperature). Once the required duration is shown on the display, touch the lock/unlock key (8) within five seconds to confirm the selection. The quick freeze symbol will stop flashing and will show on the display until the quick freeze function switches off. If the lock/unlock key is not touched within five seconds, the freezer will revert to normal operation.

To switch off the quick freeze function before the selected duration is complete, follow the steps above and cycle through the durations until the set freezer temperature shows on the display. Then touch the lock/unlock key to confirm the selection. The quick freeze symbol will no longer show on the display.

**IMPORTANT Do not use the quick freeze function for more than 48 hours.**

### Vacation mode

This appliance is equipped with a vacation mode function, which will set the freezer to -15° and switch the fridge off, maintaining frozen food during a holiday without running the fridge as well. To switch the vacation mode on, touch the vacation mode function key (3). The vacation mode symbol will show on the display and the fridge will beep to confirm the selection. To switch off the vacation mode, touch the vacation mode function key again. The vacation mode symbol will no longer show on the display.

### Setting the fridge temperature

Touch the fridge temperature key (5) so that the fridge section and the fridge temperature on the display flash. Then touch the fridge temperature key again. The temperature will cycle on the display with each touch of the key from 8° to 2° before returning to 8°.

### Quick refrigeration function

The quick refrigeration function can be used to maintain the fridge temperature when large quantities of fresh food are introduced into the fridge.

To switch on the quick refrigeration function, touch the quick refrigeration function key (6). The quick refrigeration symbol on the display will flash. Touch the lock/unlock key (8) to confirm the selection. The quick refrigeration symbol will stop flashing and will show on the display until the quick refrigeration function switches off.

To switch off the quick refrigeration function, touch the quick refrigeration function key. Then touch the lock/unlock key to confirm the selection. The quick refrigeration symbol will no longer show on the display.



### Energy saving mode

At first switch on, the fridge will work in energy saving mode, setting the freezer temperature to -15° and the fridge temperature to 7°, reducing energy consumption. To switch on the energy saving mode, touch the energy saving mode function key (7). The energy saving mode symbol will show on the display and the fridge will beep to confirm the selection. To switch off the energy saving mode, touch the energy saving mode function key again. The energy saving mode symbol will no longer show on the display.

### Safety key lock

The fridge is equipped with a safety key lock to prevent accidental reprogramming of the fridge. The key lock switches on automatically one minute after the last key touch or after the key is held in for more than ten seconds.

All keys are locked when the safety key lock is switched on except for the water filter reset key and the dispenser selection key.

To switch the safety key lock on or off, touch and hold the safety key lock button (8) for three seconds. When the lock is on, the display will show  and lock. When the lock is off, the display will show  and unlock.

## Ice and Water Dispenser

The ice-making process takes approximately two hours.

The ice maker will make ice automatically once it is switched on and will continue to make ice until the ice compartment is full. Whenever ice is removed, the ice maker will make more ice until the compartment is full again.

When crushed ice is dispensed, ensure the container is close to the nozzle to prevent spillage.

### Ice off key

The ice maker can be switched off if ice is not required. To switch off the ice maker, touch the ice off key (9). The ice off symbol will show on the display and the fridge will beep to confirm the setting.

### Dispenser selection key

The ice and water dispenser can provide ice cubes, crushed ice or cool filtered water. Touch the dispenser selection key (10) to cycle through the options. The display will show the symbol below for each option:

Once the display shows the water or ice required, place the container underneath the dispenser nozzle and push the switch back to start dispensing.

### Filter reset

When the water filter requires replacement  will show on the display. When the filter has been replaced, touch and hold the filter reset key (4) for three seconds. The water filter symbol will no longer show on the display.

Symbol	Option
	Ice cubes
	Crushed ice
	Cool water



## Installation and Ventilation

**This appliance must never be installed close to heat sources i.e. heating elements, cookers or in damp places.**

Failure to provide adequate ventilation can lead to increased running costs and premature failure and may invalidate the warranty provided with the product.

- Ensure ventilation openings are kept clear.
- Do not use a multi-purpose socket alongside other appliances.
- Do not tilt the fridge beyond 45°.
- Do not exert excessive pressure on the appliance.
- Place the refrigerator in a well-ventilated position, away from heat sources, damp and direct sunlight.
- Ensure that a gap of no less than 10cm is left above the appliance and that the gap around the outside is no less than 10cm.

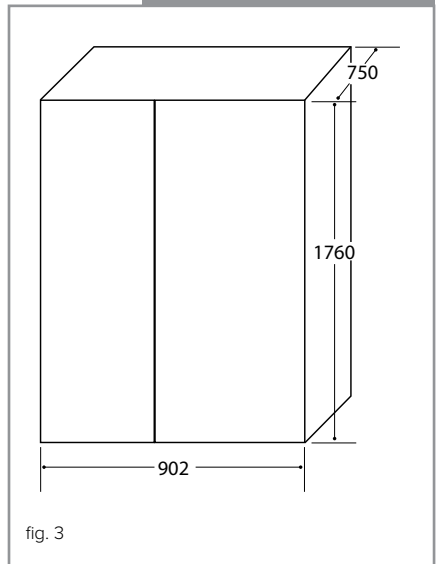

## Care and Cleaning

**IMPORTANT: Turn off the ice maker using the ice off key on the control panel before removing the ice compartment for cleaning.**

**Always disconnect the appliance from the power before any cleaning or maintenance.**

- The refrigerator and freezer sections should be cleaned using a solution of bicarbonate of soda and lukewarm water.
- Do not use abrasive products or detergents. After washing, rinse and dry thoroughly.
- Clean the shelves and balconies separately by hand using soap and water. Do not put them in the dishwasher.
- The evaporating tray and water drain hole (at the back of the refrigerator compartment) should be cleaned periodically to prevent the defrosted water from collecting inside the refrigerator compartment. The drain plug can be used to clear the drain hole.
- Once cleaning is complete, then reconnect the power.
- If the appliance is not used for prolonged periods of time, unplug and clean the appliance. The doors should be left slightly open to prevent the formation of mildew and smell.

**This appliance must never be installed close to heat sources, e.g. heating elements, cookers or in damp places.**

- The plug should be fully accessible at all times.
- To ensure the appliance is level, you should use the height adjustable feet at the front of the appliance.
- The appliance must be installed with adequate ventilation. Ensure that there is 10cm clearance above the appliance, and that there is space between the rear of the appliance and the wall.

### The water filter

The water filter should be replaced every six months approximately to ensure best performance. This duration may be reduced depending on the water quality and usage. When replacement is required, the  symbol will show on the display.

To order a replacement filter, contact CDA Customer Care.

The filter is located in the top right of the fridge compartment.

When removing the filter for replacement, place a container underneath the filter to catch any residual water which will fall.

To remove the filter, turn the filter to the left then lower out of position. To replace, push the filter upwards, and then turn it to the right.

## Troubleshooting

If you have any problems with your appliance, you should check the troubleshooting prior to calling CDA Customer Care to prevent unnecessary service calls and potential cost.

### **If the appliance is not working**

- Check there is power to the appliance:
- The house fuses are intact and the fuse in the plug has not blown.
- The plug socket is functioning fine. To check this, plug another electrical appliance in to see if the socket is working.

### **The appliance is working, but not very well**

- The appliance is not overloaded.
- The thermostat is set to an appropriate temperature.
- The doors are closing properly.
- The cooling system at the rear of the appliance is clean and free of dust, and not touching the rear wall.
- There is enough ventilation at the side and rear walls.

### **The appliance is noisy**

- The appliance is level and stable.
- The side and rear walls are clear, and there is nothing resting on the appliance.
- The cooling gas in the refrigerator will make a slight bubbling noise, even when the compressor is not running.
- It is normal for the ice and water dispenser to make noise during the ice making process and dispensing. This does not constitute a fault.

### **There is water in the lower part of the refrigerator compartment**

- The drain hole in the channel at the back of the compartment is clear.

### **The ice maker is not functioning correctly**

When the water filter is ready for replacement, the ice cubes produced will be smaller than normal.

#### **Please note:**

The LED lighting cannot be replaced without a service call. If the light fails, contact CDA Customer Care.

In the event of a power cut lasting longer than one hour, the ice cubes in the ice compartment may start to defrost. When the power returns, the ice may refreeze together which could damage the ice system. To prevent this, remove the ice in the ice compartment in the event of a power failure.

## Electrical Information

**Warning! This appliance must be earthed.**

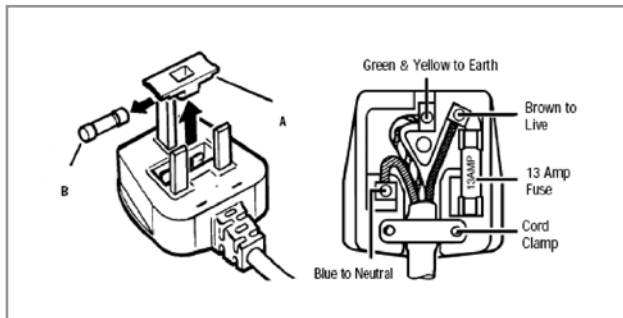

The mains lead of this appliance has been fitted with a BS 1363A 13 amp fused plug. To change a fuse in this type of plug, follow the steps below:

1. Remove the fuse cover and fuse.
2. Fit replacement 13A fuse, ASTA approved to BS 1362 type, into the fuse cover.
3. Replace fuse cover.

**Important: Do not use the appliance without the fuse cover in position.**

### How to connect an alternative plug

If the fitted plug is not suitable for your socket outlet, then it should be cut off and disposed of safely to avoid possible shock hazard. A suitable alternative plug of at least 13 Amp rating to BS 1363 should be used.

As the colours of the wires in the mains lead of this appliance may not correspond with the coloured markings identifying the terminals in your plug, proceed as follows:-

- The wire which is coloured GREEN and YELLOW must be connected to the terminal which is marked with letter (E) or by the Earth symbol  $\perp$  or coloured GREEN and YELLOW.
- The wire which is coloured BLUE must be connected to the terminal which is marked with the letter (N) or coloured BLACK.
- The wire which is coloured BROWN must be connected to the terminal which is marked with the letter (L) or coloured RED.

If in doubt regarding the electrical connection of this appliance, consult a qualified electrician. Do not shorten the supply cable, the appliance may require removing for servicing.

**N.B. Ensure that the plug socket is situated in an easily accessible place.**

**If the power supply cord is damaged, it must be replaced by a CDA authorised agent.**







E & O E. All instructions, dimensions and illustrations are provided for guidance only. CDA reserve the right to change specifications without prior notice.



To contact our Customer Care Department, or for Service,  
please contact us on the details below.