



EVS90BL

Ceiling extractor

Installation, use and maintenance



Contents:

3	Important
5	Important information
6	Using your extractor
8	Care and maintenance
9	Removing the grease filters
10 - 14	Installation
10	Installation preparation - height
11	Cut-out information
12	Fitting the extractor
13	Fitting the motor group
14	Ducting
15	Mains electricity connection
16	Electrical information
16	Troubleshooting
19	Energy Efficiency Information

Important

The CDA Group Ltd cannot be held responsible for injuries or losses caused by incorrect use or installation of this product. Please note that CDA reserve the right to invalidate the guarantee supplied with this product following incorrect installation or misuse of the appliance or use in a commercial environment.

This appliance is not designed to be used by people (including children) with reduced physical, sensorial or mental capacity, or who lack experience or knowledge about it, unless they have had supervision or instructions on how to use the appliance by someone who is responsible for their safety.

Under no circumstances, except for instructions laid out in this manual, should any external covers be removed for servicing or maintenance except by suitably qualified personnel.

Appliance information:

Please enter the details on the appliance rating plate below for reference, to assist CDA Customer Care in the event of a fault with your appliance and to register your appliance for guarantee purposes.

Appliance Model	
-----------------	--

Serial Number	
---------------	--

EU Declarations of Conformity:

This appliance has been manufactured to the strictest standards and complies with all applicable legislation, including Gas safety, Electrical safety (LVD) and Electromagnetic interference compatibility (EMC).

IMPORTANT INFORMATION FOR CORRECT DISPOSAL OF THE PRODUCT IN ACCORDANCE WITH EC DIRECTIVE 2012/19/EU.

At the end of its working life, the product must be taken to a special local authority waste collection centre or to a dealer providing appliance recycling services.

Disposing of a household appliance separately avoids possible negative consequences for the environment and health. It also enables the constituent materials to be recovered, saving both energy and resources. As a reminder of the need to dispose of household appliances separately, the product is marked with a crossed-out wheeled dustbin. 

IMPORTANT:

- Under no circumstances should the extractor be connected to any gas ventilation system, flue system or hot air ducting system.
- Do not vent the extractor into an attic or loft space.
- Only house the extractor in rooms with adequate ventilation. Remember that the extractor is powerful and whatever air is extracted needs to be replaced.
- Do not tile the extractor in. It should be removable for service or maintenance.
- Do not use silicone sealant to secure the hood to the wall.
- You must be able to isolate the extractor from the mains electrical supply after installation.
- This extractor has been designed to be used in a room with a volume of less than 36m³.
- Steam cleaners must not be used when cleaning this appliance.
- The performance of your extractor will vary depending on a number of factors. These include: type of extraction, length of ducting, room volume, ventilation available and cleanliness of the filters.
- The extractor, when extracting air, could generate a negative pressure in the room which can't exceed 0.04 mbar. Ensure that there are air intakes allowing a constant flow of fresh air within the room in which the extractor is installed. Ventilation for gas fuelled appliances must be as per regulations in force.

Using your extractor

For best performance, you should switch on the extractor 15 minutes before starting to cook and leave it to run for approximately 15 minutes after the end of cooking (you can use the timer function for this).

- 1 - On/off button
- 2 - Speed increase button
- 3 - Speed decrease button
- 4 - Light button

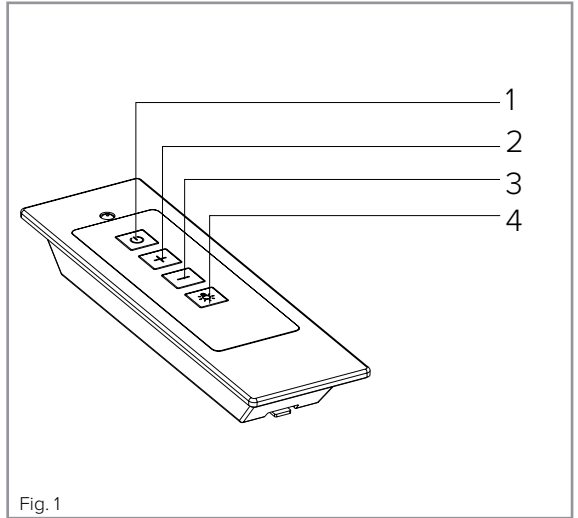

Switching the extractor on/off and setting the speed level

- Press the on/off button. The appliance will switch on at speed level 1.
- To increase the speed level touch the speed increase button. Red LED indicators will illuminate according to the set speed.
- To reduce the speed level touch the speed decrease button.
- To switch the extractor off, touch the on/off button.

Extractor lights

- To switch the lights on and off, press button 4 on the remote control.

Please note: The lights are not intended to provide downlight illumination.

Timer

The extractor is equipped with a timer that allows the extractor to run for 15 minutes before switching off automatically.

- To activate the timer, set the desired speed and then press and hold the speed decrease button (3) for approximately two seconds. The LED indicator for the speed on the extractor body will flash to confirm the timer is active.
- To cancel the timer, press either the speed increase button, speed decrease button or the on/off button.

Please note: The timer can be activated on any speed.

Care and maintenance

IMPORTANT: DO NOT PERFORM MAINTENANCE OR ATTEMPT TO CLEAN THE EXTRACTOR WITHOUT FIRST SWITCHING OFF THE ELECTRICITY SUPPLY. ALWAYS WEAR ADEQUATE PPE (PERSONAL PROTECTIVE EQUIPMENT) FOR THE TASK AT HAND.

Cleaning

You should use a non-abrasive cleaner. Any abrasive cleaner (including Cif) will scratch the surface and could erase the control panel markings.

You can clean your extractor effectively by using a dilute solution of water and mild detergent and drying to a shine with a clean cloth.

IMPORTANT:

Always protect surfaces immediately beneath the extractor (such as a hob) with clean, dry towels or similar cushioning items before carrying out any cleaning or maintenance in case of falling parts/ items.

Cleaning the grease filters

The grease filters should be kept clean to minimise the risk of fire.

At least once a month you should remove and clean the grease filters with hot soapy water. You can also wash the grease filters in a dishwasher, ensuring that you place them in an upright position to prevent damage from other items in the dishwasher. After rinsing and drying, replace the filters. **Please note** that washing the filters in a dishwasher can lead to discolouration. This is not a fault.

To remove the grease filters follow these steps:

1. Open the cover panel by pulling down on the LED indicator side.
The panel will lower as far as the hydraulic arms permit.
2. Pull down the handle on each grease filter. It will release at the handle side. Then, lower the grease filter to remove it completely.

Please note: Releasing the grease filters, when the extractor is installed, could cause them to fall. Take care and ensure you remove them safely. Protect any surfaces below accordingly.

To replace the grease filters, repeat the above steps in reverse.

This appliance is fitted with energy saving LED lighting that has a considerably longer life expectancy than traditional filament bulbs. These are not user-replaceable. In the unlikely event of a failure please contact CDA Customer Care using the details on page 17.

The lighting is designed for aesthetic purposes and not for general room, nor down-light, illumination. Extended use of the lights can reduce their life span.

Installation preparation

When installing this product we recommend you seek the help of at least two other individuals. This product may have some sharp edges. Please take care and wear adequate PPE (Personal Protective Equipment) when handling.

Installation preparation - height

IMPORTANT:

When the extractor is to be installed above a **CDA electric hob**, the minimum distance between the hob and the downwards-facing side of the extractor must exceed 650mm.

When the extractor is to be installed above a **CDA gas hob**, the minimum distance between the hob and the downwards-facing side of the extractor must exceed 650mm.

If the instructions provided with your gas hob state that the required distance between the hob and extractor must be greater than our measurement, then that is the distance that should be observed; this is a legal requirement and may lead to your hob being disconnected from the gas supply and the installation being reported under RIDDOR (the height should be measured from the top of the burners).

IN THE ABSENCE OF ANY INSTRUCTIONS SUPPLIED WITH A GAS HOB, THE MINIMUM DISTANCE BETWEEN THE HOB AND EXTRACTOR MUST BE AT LEAST 760mm. The width of a hob must not be greater than the width of the extractor installed above it.

IMPORTANT: Ensure that any false ceiling will be capable of supporting the weight of the product, which is approximately 18.7 kg (without the motor group). Your motor group should be mounted onto a solid ceiling or wall.

Below (Fig. 2) is a diagram showing the overall extractor dimensions. This is to aid you in preparation for installing the extractor.

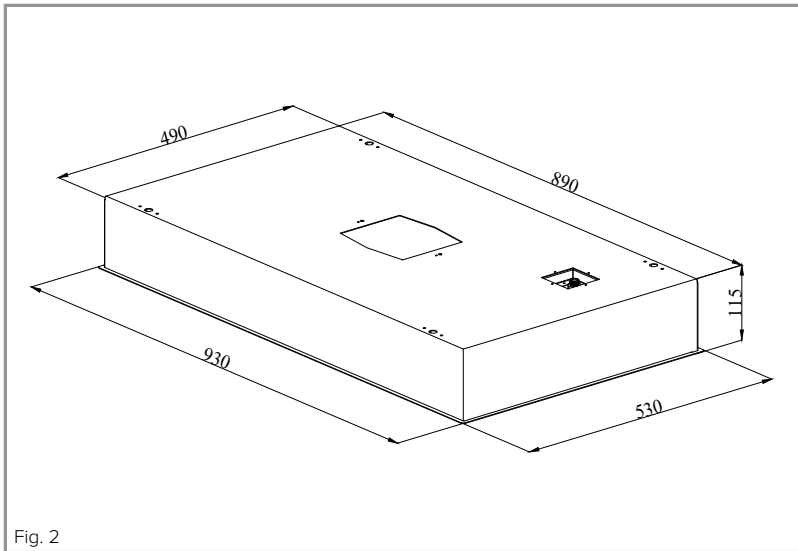

Recommended niche/cut-out dimensions (due to hanging hooks)
= 900 x 500 mm

Please note: If the nature of the install is such that you will not be able to install the motor group and subsequent ducting once the extractor body has been installed, then you will need to fit the motor group and ducting now (i.e. before mounting the extractor body into the cut-out).

Remember: Always bear servicing in mind. Always ensure that the motor group is accessible after installation (e.g. access panel).

Installation - fitting the extractor

Offer up the extractor to the cut-out/niche that you have prepared. You may have to manoeuvre it slightly to get the extractor and hangar hooks (A,B,C and D in Fig. 3) into the cut-out. With at least two others supporting the extractor, tighten the screws that are accessible through four holes on the downwards facing side of the extractor (Fig. 5) in roughly the same positions as A,B,C and D in Fig. 3.

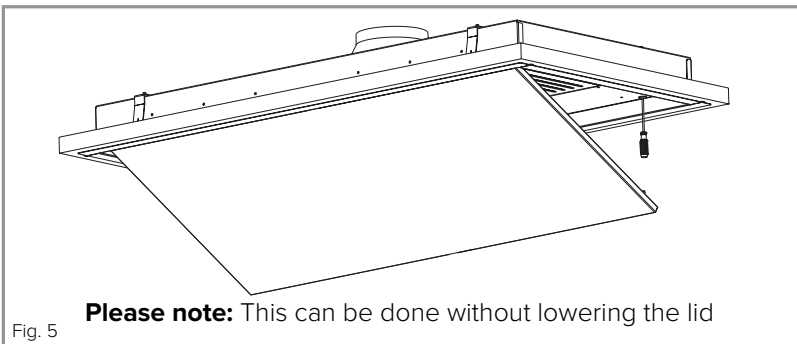
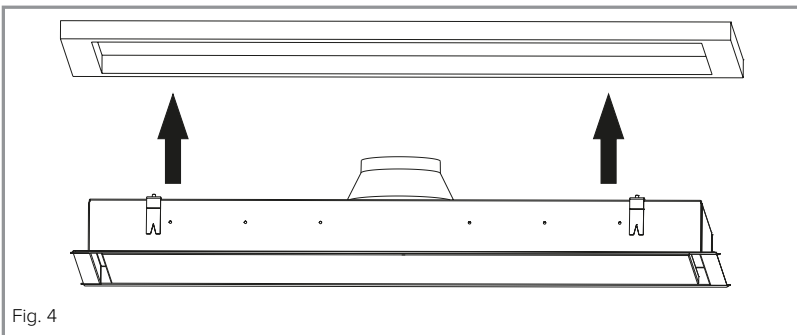
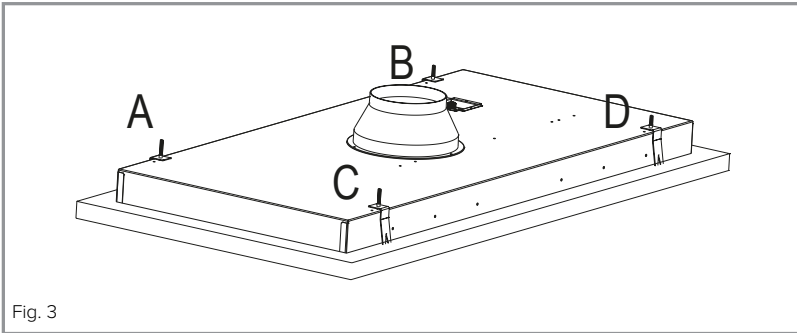

Please note: This can be done without lowering the lid

Installation - fitting the motor group

The motor group can be placed wherever is most convenient. We strongly recommend that the motor group is fitted to a solid ceiling or wall. There are four screw holes on one of the motor group sides to facilitate this.

Please bear in mind, when installing the motor, the information on ducting and distance/bends on page 14. Always bear servicing in mind. Always ensure that the motor group is accessible after installation (e.g. access panel).

Once the motor group is secured in position, connect the ducting adapter (**A**) to the motor group using two screws, as per Fig 6.

Connect the ducting to the extractor body outlet and then secure it to the ducting adapter (or vice versa). Use jubilee clips or a similar means to ensure a good, secure connection.

Connect ducting to the motor group outlet and run it to the destination point. Make any connections secure with jubilee clips or similar.

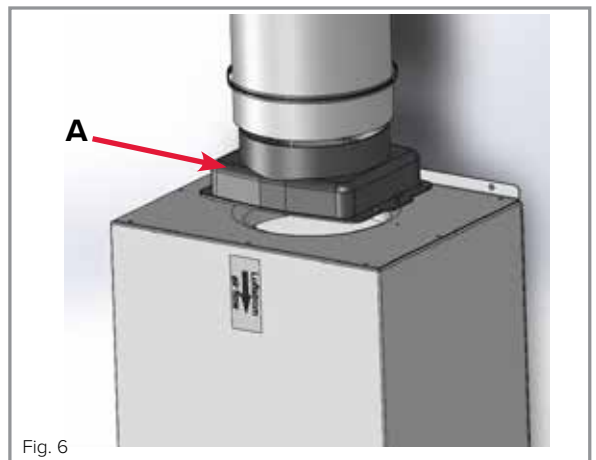

Fig. 6

Ducting

The ducting used should be 150mm, rigid circular pipe and must be manufactured from fire retardant material, produced to BS 476 or DIN 4102-B1.

Wherever possible utilise rigid circular pipe which has a smooth interior, rather than the expanding concertina type ducting. The lengths of ducting with minimal effect on performance are as follows:

- 4 metres with 1 x 90° bend.
- 3 metres with 2 x 90° bends.
- 2 metres with 3 x 90° bends.

Longer ducting can be used but the performance of the extractor will likely be reduced.

Please note: Ducting components and ducting kits are optional accessories and have to be ordered, they are not automatically supplied with the hood. Use of ducting less than 150mm in diameter will affect performance and increase the noise produced by the extractor.

Note that the ducting should be secured and sealed to the vent outlet pipe / valve using appropriate jubilee clips or securing means.

Mains electricity connection

THIS APPLIANCE MUST BE CONNECTED TO THE MAINS SUPPLY BY A COMPETENT PERSON, USING FIXED WIRING VIA A DOUBLE POLE SWITCHED FUSE SPUR OUTLET AND PROTECTED BY A 3A FUSE.

Warning! This appliance must be earthed

We recommend that the appliance is connected by a qualified electrician, who is a member of the N.I.C.E.I.C. and who will comply with the I.E.T. and local regulations.

The wires in the mains lead of this appliance are coloured in accordance with the following code:

Green & Yellow = Earth

Blue = Neutral

Brown = Live.

As the colours of the wires in the mains lead for the appliance may not correspond with the coloured markings identifying the terminals connecting to the fuse spur, proceed as follows:

- The wire which is coloured green and yellow must be connected to the terminal marked E (Earth) or coloured green.
- The wire which is coloured blue must be connected to the terminal marked N (Neutral) or coloured black.
- The wire which is coloured brown must be connected to the terminal marked L (Live) or coloured red.

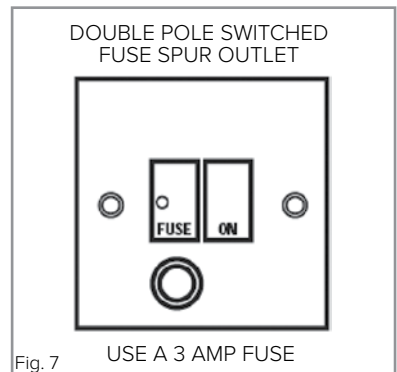

Note: Use a 3A Fuse

Assembly and electrical connection should be carried out by specialised personnel.

The mains isolation switch should be readily accessible after the appliance has been installed and it is recommended that the isolation switch is located within 2m of the appliance, where practical.

This appliance is intended to be connected to the mains electrical supply by means of an isolation switch and fused spur and is intended to be protected by a 3A fuse. The use of a 13A fuse can cause damage to the internal wiring in the event of a fault, and may also invalidate the warranty.

Electrical information

Mains electrical voltage: 220 – 240Vac

Total rated power consumption: 374W

Troubleshooting

If your extractor is not working:

1. Check that the mains supply has not been switched off.
2. Check that the fuse in the spur has not blown.
3. Check that the batteries in your remote do not need replacing.
4. Check that the mains switch inside the extractor has not been switched off. This switch is shown in Fig. 8 on page 17.



Fig. 8

If your lights are not working:

1. Check that the mains supply has not been switched off.
2. Check whether the extractor still extracts on any speed. If not, check the fuse and remote batteries, as above. If the lights still do not work, contact CDA Customer Care. Contact details are on page 17.

If the remote control is responding incorrectly or not at all:

1. Ensure that the lenses on the remote and the extractor underside (next to the red LED speed indicators) are clean and free from grime, grease and other residues.
2. Check that no other infrared operated devices are clashing with the operation of your extractor.
3. Check the batteries within the remote control.

If any of the potential resolutions in this guide do not resolve your issue, please contact:

Contact CDA Customer Care

A: Customer Care Department, The CDA Group Ltd, Harby Road,
Langar, Nottinghamshire, NG13 9HY

T: 01949 862 012

F: 01949 862 003

E: customer.care@cda.eu

W: www.cda.eu

NOTES:

Energy Efficiency Information

Attribute	Symbol	Value	Units
Model Identification		EVS90	
Annual Energy Consumption	AEC_{Hood}	118	kWh
Time increase factor	f	1.3	
Fluid Dynamic Efficiency	FDE_{Hood}	19.6 (C)	
Energy Efficiency Index	EEl_{Hood}	80.9 (C)	
Measured airflow at Best Efficiency Point	Q_{BEP}	424.8	m^3/h
Measured Pressure at Best Efficiency Point	P_{BEP}	360	Pa
Maximum airflow	Q_{MAX}	615	m^3/h
Measured electric power at Best Efficiency Point	W_{BEP}	216.9	W
Nominal lighting power	WL	19	W
Average illumination of the lighting system on the cooking surface	E_{Middle}	215	Lux
Measured power consumption in standby	P_S	0.39	W
Measured power consumption off mode	P_O	0	W
Sound power level	L_{WA}	62	dBA
Grease Filter Efficiency	GFE_{Hood}	76.1 (C)	%
Lamp efficiency	LE_{Hood}	15 (D)	%

E & O E. All instructions, dimensions and illustrations are provided for guidance only. CDA reserve the right to change specifications without prior notice.



For service or queries relating to your product please contact:

The Customer Care Department on **01949 862 012** or email customer.care@cda.eu

For more information please contact:

The Sales Department on **01949 862 010** or email sales@cda.eu

Customer Care Department. The CDA Group Ltd, Harby Road, Langar, Nottinghamshire, NG13 9HY
T: 01949 862 012 F: 01949 862 003 E: customer.care@cda.eu